

# GP Lam<sup>®</sup> LVL



Grade	Thickness	Depth
2.0E	1¾", 3½"	7¼", 9¼", 9½", 11¼", 11⅞", 14", 16", 18", 24" (20" and 22" by special order)
1.5E	1¾"	7¼", 9¼", 9½", 11¼", 11⅞", 14", 16"
	3½"	4⅝", 5½", 7¼", 9¼", 9½", 11¼", 11⅞", 14", 16"

**Lengths:** up to 60 feet.

Referenced dimensions are nominal and used for design purposes.

## Structural Support for Today's Homes

Today, home designs often include grand entrances, wider doorways between rooms, and dramatic window configurations. GP Lam® LVL is designed for use as floor beams; door, window and garage door headers; and ridge and hip beams.

Multiple pieces of GP Lam LVL can be assembled easily to obtain greater thicknesses, providing additional strength to carry heavier loads. Greater load capacity means longer, uninterrupted spans.

For better performance, GP Lam LVL features FiberGuard™ sealant to minimize cupping and warping due to moisture damage while in storage and transit to the jobsite. The LVL is evenly coated on all four sides and both ends with a modified acrylic emulsion film,

helping to reduce the moisture absorption rate and to reduce the damage that an unprotected product may sustain. FiberGuard sealant also includes UV inhibitors to minimize color change caused by the sun's ultraviolet rays.



### GP Lam® LVL Features & Benefits

- Available in two thicknesses:
  - 3½" one piece member helps reduce installation time
  - 1¾" member for versatility
- Value Lengths of 24', 28', 32', 36', 40', 44' and 48' (lengths to 60' by special order)
- 2.0E has high design values for bending, stiffness and shear strength
- 1.5E is great for lower stress applications such as window and door headers
- Higher strength-to-weight ratio than solid sawn lumber
- Consistent manufacturing minimizes defects and reduces waste on the job
- Installs as easily as ordinary lumber
- FiberGuard® coating with UV inhibitors offers jobsite protection from moisture
- Backed by a Lifetime Limited Warranty\*



\* See manufacturer's warranty for terms, conditions and limitations, available at [www.gp.com/build](http://www.gp.com/build) or by calling 800-284-9759.

## GP Lam<sup>®</sup> LVL Bearing Details

- Confirm the actual required bearing is provided by a support that has adequate strength to carry the load.
- Minimum bearing length for GP Lam LVL beams and headers is 1½" for end and 3" for intermediate bearings. Size bearing for applied loads.
- For fastening recommendations for multiple-ply GP Lam LVL members, see pages 51-53.

### Beam-to-Beam Connection

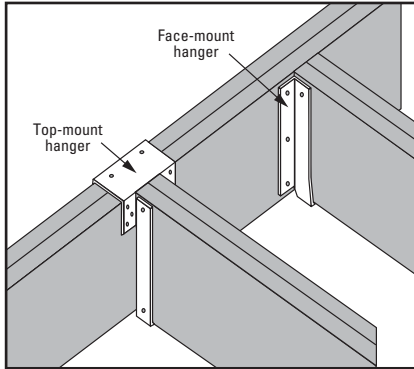

Hangers must be properly installed to achieve full capacity.

### Bearing on Wood Column

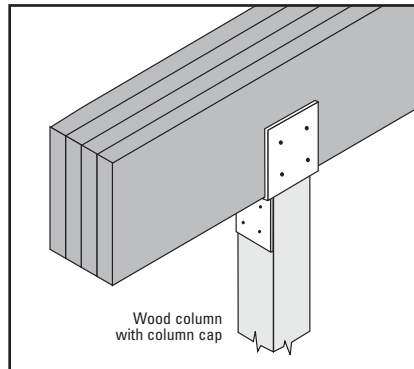

Where column caps are not used, side plates may be required for lateral restraint and/or load transfer. Consult designer of record. See tables on page 56 and 57 for column cap suggestions.

### Bearing on Steel Column

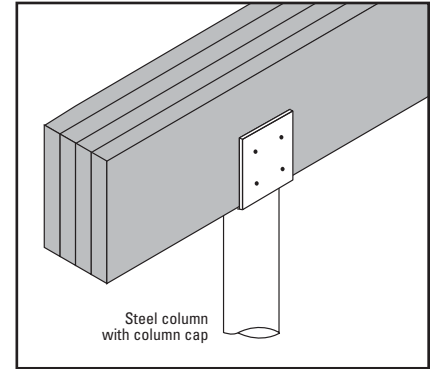

### Pocket in Concrete or Masonry

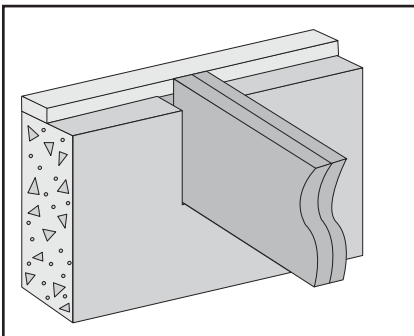

Prevent direct contact of GP Lam LVL with concrete or masonry, or protect per code. Consult local building code for additional requirements.

### Bearing on Exterior Wall

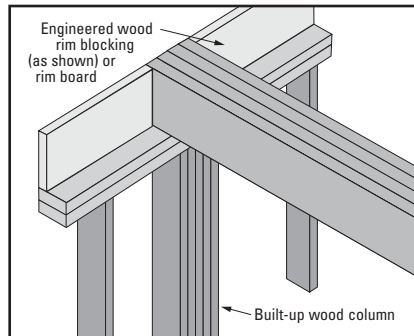

Consult local building code for requirements.

### Bearing for Door or Window Header

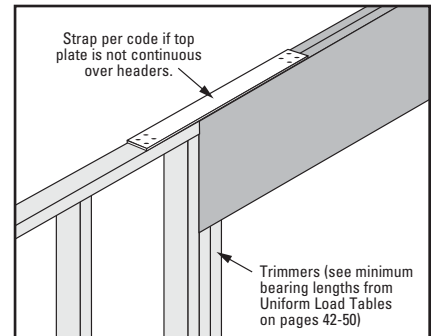

See "Bearing Length Requirements" on page 40.

### Low End Hip Bearing

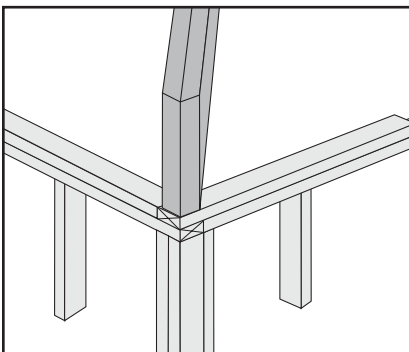

Hip beam must bear completely on plate or post. Seat cut must not extend past inside face of bearing.

### High End Hip Bearing

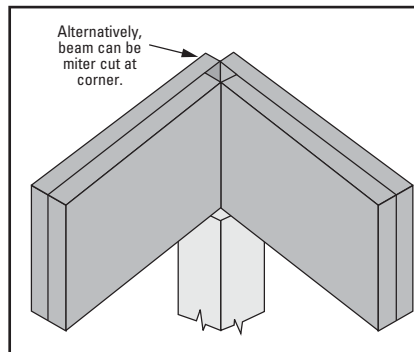

Hip beam must bear on post or in properly designed hanger or other connection.

### Seat Cut / Notching

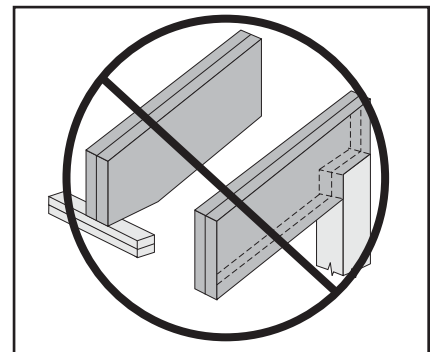

Seat cut must not extend past inside face of bearing. Do not notch beams at bearing.

# GP Lam® LVL Handling & Installation

- GP Lam® LVL shall not be stored in direct contact with the ground and must be protected from weather. Provide air circulation under covering and around stacks of materials.
- Bundles must be stored level and must not be opened until time of installation.
- Stack and handle GP Lam LVL flatwise.
- Handlers and installers should use appropriate personal protective equipment such as gloves and goggles. An MSDS is available at [www.gp.com/build](http://www.gp.com/build).
- Engineered lumber must not be installed in direct contact with concrete or masonry construction or shall be protected per code and shall be used in covered, dry use conditions only (moisture content is less than 16%).
- Minimum bearing length for GP Lam LVL beams and headers: end bearing 1½", intermediate bearing 3". Size for applied loads.
- GP Lam LVL beams and headers must be restrained against rotation at ends and supports and the top (or compression edge) must be laterally supported by perpendicular framing or bracing at 24" on-center or closer.
- 1¾" GP Lam LVL beams deeper than 14" must only be used in multiple-piece members.
- Nails installed in the narrow face of GP Lam LVL shall not be spaced closer than 4" (10d common nails) or 3" (8d common nails).
- Multiple piece GP Lam LVL may not be stagger-spliced as is commonly done with dimension lumber. If the required length of a multiple-span beam exceeds the available length of the LVL, the LVL beams must be installed so as to butt together over a common bearing.
- GP Lam LVL is manufactured without camber or specific vertical orientation. It may be installed with the identifying stamps on the side faces reading right side up or upside down.
- Strength and stiffness properties of GP Lam LVL exceed those of typical dimension lumber. It may be possible to substitute GP Lam LVL for dimension lumber roof members in code-prescribed conventional light-frame construction, but design of conventional construction is beyond the scope of this product guide and of Georgia-Pacific Engineered Lumber Technical Services.
- When nail type is not specified in this guide, use common, box or sinker.
- To help safeguard the structural integrity of connections with preservative or fire-retardant treated wood, use only hot-dipped galvanized or stainless steel fasteners, connectors and hardware as required by code and type of treatment.
  - As a minimum requirement, hot-dipped galvanized coated fasteners should conform to ASTM Standard A 153 and hot-dipped galvanized coated connectors should conform to ASTM Standard A 653 (Class G-185). In demanding applications, or in highly corrosive environments, stainless steel fasteners and connectors should be utilized and may, in fact, be required by building codes.
  - Most commonly available electroplated galvanized fasteners do not have a sufficient coating of zinc and are not recommended. Aluminum should not be used in direct contact with preservative treated wood. Never mix galvanized steel with stainless steel in the same connection.**

## 2.0E GP Lam LVL Floor Beams

This table shows the size (e.g.: 2-11¼" = 2 plies of 1¾"x11¼") of beams needed to support loads of one floor only, i.e., a second story floor or one story floor over a basement. (See drawing at right.)

When floor joists span continuously from wall to wall (not cut at beam) this table requires that "B" be not less than 45%, or greater than 55% of "A".

Example: If "A" = 32', "B" must be between 14.4' (32 x .45) and 17.6' (32 x .55)

For non-conforming situations, use FASTBeam® analysis and selection software or contact Georgia-Pacific.

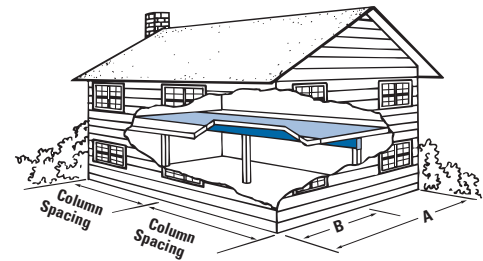

		Column or Support Spacing (center-to-center)									
		11'	12'	13'	14'	15'	16'	17'	18'	19'	20'
Total Floor Joist Span "A"	24'	2-11¼" 3-9¼"	2-11¼" 3-9½"	2-11⅝" 3-11¼"	2-14" 3-11¼"	2-14" 3-11⅝"	2-16"+ 3-14"	2-16"+ 3-14"	2-18"+ 3-16"	2-18"+ 3-16"	2-18"+ 3-16"
	28'	2-11¼" 3-9¼"	2-11⅝" 3-11¼"	2-14"+ 3-11¼"	2-14"+ 3-11⅝"	2-16"+ 3-14"	2-16"+ 3-14"	2-16"+ 3-14"	2-18"+ 3-16"	2-18"+ 3-16"	3-16"
	32'	2-11¼"	2-14"+ 3-11¼"	2-14"+ 3-11⅝"	2-14"+	2-16"+ 3-14"	2-16"+ 3-14"	2-18"+ 3-16"	2-18"+ 3-16"	3-16"+	3-18"+
	36'	2-11⅝"+ 3-11¼"	2-14"+ 3-11¼"	2-14"+ 3-11⅝"	2-16"+ 3-14"	2-16"+ 3-14"	2-18"+ 3-14"	3-16"+	3-16"+	3-18"+	3-18"+
	40'	2-11⅝"+ 3-11¼"	2-14"+ 3-11¼"	2-14"+	2-16"+ 3-14"	2-16"+ 3-14"	3-16"+	3-16"+	3-16"+	3-18"+	3-18"+

+ See note 2.

### NOTES:

1. Table is based on continuous floor joist span and simple or continuous beam span conditions. If floor joists are not continuous above the beam, take the sum of the joist spans then multiply by 0.8. This is the total floor joist span to consider.
2. Required end bearing length (based on 565 psi) is 3.0" unless the subscript + is shown. In that case, 4.5" is required.
3. At intermediate supports of continuous spans, use the following guidelines or refer to page 40.
  - 7½" bearing length for beams requiring 3" bearing at the beam ends
  - 10½" bearing length for beams requiring 4½" bearing at the beam ends
4. All headers require full-width bearing support, e.g., 2x6 for 5¼", 3-ply members. The adequacy of supporting columns to be verified by others.
5. Table is based on residential floor loading of 40 psf live load and 12 psf dead load.
6. Live load reductions have been applied per IBC section 1607.9.1.
7. Deflection is limited to L/360 at live load and L/240 at total load.
8. For other uniform load conditions refer to pages 42-43.
9. A single 3½" thick ply can be substituted for any two 1¾" thick plies.
10. For multiple ply fasteners, see pages 51-53.

## 2.0E GP Lam® LVL Window and Patio Door Headers, 2-Story

### Two-Story Applications

This table shows the size (e.g.: 2-11¼" = 2 plies of 1¾" x 11¼") of beams needed to support the combined loads from a wall, second story floor (¼ of total floor joist span) and various roof truss spans with a 2' soffit. If the soffit exceeds 2', additional design is necessary.

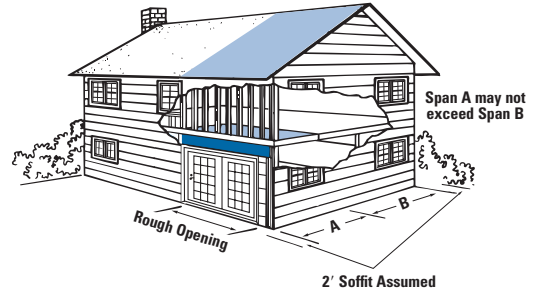

Roof Loading	Snow (115%)										Non-Snow (125%)										
	25 psf LL + 20 psf DL					40 psf LL + 20 psf DL					20 psf LL + 15 psf DL					20 psf LL + 25 psf DL					
Rough Opening	6'	8'	9'	10'	12'	6'	8'	9'	10'	12'	6'	8'	9'	10'	12'	6'	8'	9'	10'	12'	
Roof Truss Span with 2' Soffit Assumed	20'	1-9/16" 2-7/16"	1-11/16" 2-9/16" 3-7/16"	1-14" 2-11/16" 3-9/16"	2-11/16"	2-16" 3-14"	1-9/16" 2-7/16"	1-11/16" 2-9/16"	2-11/16" 3-9/16"	2-14" 3-11/16"	2-16" 3-14"	1-7/16"	1-11/16" 2-9/16" 3-7/16"	1-14" 2-9/16"	2-11/16" 3-9/16" 3-11/16"	2-14"	1-9/16" 2-7/16"	1-11/16" 2-9/16"	1-14" 2-11/16" 3-9/16"	2-11/16"	2-16" 3-14"
	24'	1-9/16" 2-7/16"	1-11/16" 2-9/16"	1-14" 2-11/16" 3-9/16"	2-11/16"	2-16" 3-14"	1-9/16" 2-7/16"	1-11/16" 2-9/16"	2-11/16" 3-9/16"	2-14" 3-11/16"	2-18" 3-14"	1-9/16" 2-7/16"	1-11/16" 2-9/16"	1-14" 2-11/16" 3-9/16"	2-11/16"	2-16" 3-14"	1-9/16" 2-7/16"	1-11/16" 2-9/16"	1-14" 2-11/16" 3-9/16"	2-11/16"	2-16" 3-14"
	28'	1-9/16" 2-7/16"	2-9/16"	2-11/16" 3-9/16"	2-14" 3-11/16"	2-16" 3-14"	1-9/16" 2-7/16"	2-11/16" 3-9/16"	2-11/16" 3-11/16"	2-14" 3-11/16"	2-18" 3-16"	1-9/16" 2-7/16"	1-11/16" 2-9/16"	1-14" 2-11/16" 3-9/16"	2-11/16"	2-16" 3-14"	1-9/16" 2-7/16"	2-9/16"	2-11/16" 3-9/16"	2-14" 3-11/16"	2-16" 3-14"
	32'	1-9/16" 2-7/16"	2-11/16" 3-9/16"	2-11/16"	2-14" 3-11/16"	2-18" 3-16"	2-7/16"	2-11/16" 3-9/16"	2-14" 3-11/16"	2-16" 3-11/16"	3-16"+	1-9/16" 2-7/16"	1-14" 2-9/16"	2-11/16" 3-9/16"	2-14" 3-11/16"	2-16" 3-14"	1-9/16" 2-7/16"	2-11/16" 3-9/16"	2-11/16"	2-14" 3-11/16"	2-18" 3-16"
	36'	1-9/16" 2-7/16"	2-11/16" 3-9/16"	2-11/16" 3-11/16"	2-14" 3-11/16"	2-18" 3-16"	2-9/16" 3-7/16"	2-11/16" 3-9/16"	2-14" 3-11/16"	2-16" 3-14"	3-16"+	1-9/16" 2-7/16"	2-9/16" 3-9/16"	2-11/16" 3-11/16"	2-14" 3-11/16"	2-18" 3-14"	1-9/16" 2-7/16"	2-11/16" 3-9/16"	2-11/16" 3-11/16"	2-14" 3-11/16"	2-18" 3-16"

+ See note 1.

#### NOTES:

- Required end bearing length (based on 625 psi) is 3.0" unless the subscript + is shown. In that case, 4.5" is required.
- All headers require full-width bearing support, e.g., 2x6 for 5¼", 3-ply members. The adequacy of supporting columns to be verified by others.
- Table is based on residential floor loading of 40 psf live load and 12 psf dead load and exterior wall weight of 100 plf.
- A beam line supporting the center of the second floor is assumed.
- Deflection is limited to L/360 and the lesser of L/240 or 5/16" at total load.
- Roof live and dead loads shown are applied vertically to the horizontal projection.
- When using a single ply 1¾", consider the effect on hanger capacity, and the available bearing surface the LVL provides to other framing elements.
- A single 3½" thick ply can be substituted for any two 1¾" thick plies.
- For multiple ply fasteners, see pages 51-53.

## 2.0E GP Lam LVL Garage Door Headers, 2-Story

### Two-Story Applications

This table shows the size (e.g.: 2-11¼" = 2 plies of 1¾" x 11¼") of beams needed to support the combined loads from a wall, second story floor (¼ of total floor joist span) and various roof truss spans with a 2' soffit. If the soffit exceeds 2', additional design is necessary.

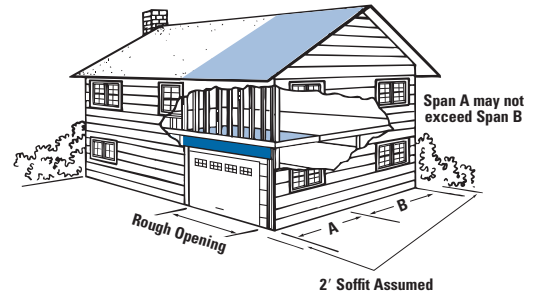

Roof Loading	Snow (115%)									Non-Snow (125%)									
	25 psf LL + 20 psf DL			30 psf LL + 20 psf DL			40 psf LL + 20 psf DL			20 psf LL + 15 psf DL			20 psf LL + 20 psf DL			20 psf LL + 25 psf DL			
Rough Opening	9'3"	16'3"	18'3"	9'3"	16'3"	18'3"	9'3"	16'3"	18'3"	9'3"	16'3"	18'3"	9'3"	16'3"	18'3"	9'3"	16'3"	18'3"	
Roof Truss Span with 2' Soffit Assumed	20'	1-11/16" 2-9/16"	2-16" 3-14"	2-18" 3-16"	1-11/16" 2-9/16"	2-16" 3-14"	2-18" 3-16"	2-9/16" 3-9/16"	2-18" 3-14"	3-16"+	1-11/16" 2-9/16"	2-16" 3-14"	2-18" 3-16"	1-11/16" 2-9/16"	2-16" 3-14"	2-18" 3-16"	1-11/16" 2-9/16"	2-16" 3-14"	2-18" 3-16"
	24'	2-9/16"	2-18" 3-14"	3-16"	2-9/16" 3-9/16"	2-18" 3-16"	3-16"+	2-11/16" 3-9/16"	3-16"+	3-18"+	1-11/16" 2-9/16"	2-16" 3-14"	2-18" 3-16"	1-11/16" 2-9/16"	2-16" 3-14"	2-18" 3-16"	2-9/16"	2-18" 3-14"	3-16"
	28'	2-11/16" 3-9/16"	3-16"+	3-18"+	2-11/16" 3-9/16"	3-16"+	3-18"+	2-11/16" 3-9/16"	3-16"+	3-18"+	2-9/16"	2-16" 3-14"	2-18" 3-16"	2-9/16" 3-9/16"	2-18" 3-16"	3-16"+	2-11/16" 3-9/16"	3-16"+	3-18"+
	32'	2-11/16" 3-9/16"	3-16"+	3-18"+	2-11/16" 3-9/16"	3-16"+	3-18"+	2-11/16" 3-9/16"	3-16"+	3-18"+	2-9/16" 3-9/16"	2-18" 3-16"	3-18"+	2-11/16" 3-9/16"	3-16"+	3-18"+	2-11/16" 3-9/16"	3-16"+	3-18"+
	36'	2-11/16" 3-9/16"	3-16"+	3-18"+	2-11/16" 3-9/16"	3-16"+	3-18"+	2-11/16" 3-9/16"	3-16"+	3-18"+	2-11/16" 3-9/16"	2-18" 3-16"	3-18"+	2-11/16" 3-9/16"	3-16"+	3-18"+	2-11/16" 3-9/16"	3-16"+	3-18"+

+ See note 1.

#### NOTES:

- Required end bearing length (based on 625 psi) is 3.0" unless the subscript + is shown. In that case, 4.5" is required.
- All headers require full-width bearing support, e.g., 2x6 for 5¼", 3-ply members. The adequacy of supporting columns to be verified by others.
- Table is based on residential floor loading of 40 psf live load and 12 psf dead load and exterior wall weight of 100 plf.
- A beam line supporting the center of the second floor is assumed.
- Deflection is limited to L/360 at live load and L/240 at total load.
- Roof live and dead loads shown are applied vertically to the horizontal projection.
- When using a single ply 1¾", consider the effect on hanger capacity, and the available bearing surface the LVL provides to other framing elements.
- A single 3½" thick ply can be substituted for any two 1¾" thick plies.
- For multiple ply fasteners, see pages 51-53.

## 2.0E GP Lam<sup>®</sup> LVL Window and Patio Door Headers, Roof Only

### Roof Applications

This table shows the size (e.g.: 2-11¼" = 2 plies of 1¾" x 11¼") of headers needed to support various roof truss spans with 2' soffit. If the soffit is greater than 2', additional design is necessary.

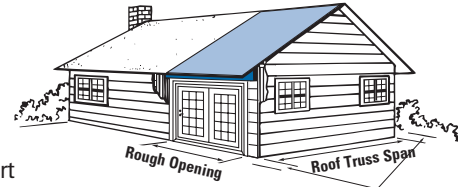

2' Soffit Assumed

Roof Loading	Rough Opening	Snow (115%)										Non-Snow (125%)									
		25 psf LL + 20 psf DL					40 psf LL + 20 psf DL					20 psf LL + 15 psf DL					20 psf LL + 25 psf DL				
		6'	8'	9'	10'	12'	6'	8'	9'	10'	12'	6'	8'	9'	10'	12'	6'	8'	9'	10'	12'
Roof Truss Span with 2' Soffit Assumed	20'	1-7/8"	1-9/8"	1-11/8"	1-14"	1-7/8"	1-11/8"	1-11/8"	1-14"	1-14"	1-7/8"	1-9/8"	1-9/8"	1-11/8"	1-14"	1-7/8"	1-9/8"	1-11/8"	1-14"	1-14"	1-14"
	24'	1-7/8"	1-9/8"	1-11/8"	1-14"	1-7/8"	1-11/8"	1-14"	1-14"	1-14"	1-7/8"	1-9/8"	1-11/8"	1-11/8"	1-14"	1-7/8"	1-9/8"	1-11/8"	1-14"	1-14"	1-14"
	28'	1-7/8"	1-11/8"	1-11/8"	1-14"	1-9/8"	1-11/8"	1-14"	1-14"	1-14"	1-7/8"	1-9/8"	1-11/8"	1-14"	1-14"	1-7/8"	1-11/8"	1-11/8"	1-14"	1-14"	1-14"
	32'	1-7/8"	1-11/8"	1-14"	1-14"	1-9/8"	1-11/8"	1-14"	1-14"	1-14"	1-7/8"	1-9/8"	1-11/8"	1-14"	1-14"	1-7/8"	1-11/8"	1-14"	1-14"	1-14"	1-14"
	36'	1-9/8"	1-11/8"	1-14"	1-14"	1-9/8"	1-11/8"	1-14"	1-14"	1-14"	1-7/8"	1-11/8"	1-14"	1-14"	1-14"	1-7/8"	1-11/8"	1-14"	1-14"	1-14"	1-14"

+ See note 1.

#### NOTES:

- Required bearing length (based on 625 psi) is 3.0" unless the subscript + is shown. In that case, 4.5" is required.
- All headers require full-width bearing support, e.g., 2x6 for 5¼", 3-ply members. The adequacy of supporting columns to be verified by others.
- Deflection is limited to L/240 at live load and the lesser of L/180 or 5/16" at total load.
- Roof live and dead loads shown are applied vertically to the horizontal projection.
- When using a single ply 1¾", consider the effect on hanger capacity, and the available bearing surface the LVL provides to other framing elements.
- A single 3/8" thick ply can be substituted for any two 1/4" thick plies.
- For multiple ply fasteners, see pages 51-53.

## 2.0E GP Lam LVL Garage Door Headers, Roof Only

### Roof Applications

This table shows the size (e.g.: 2-11¼" = 2 plies of 1¾" x 11¼") of headers needed to support various roof truss spans with 2' soffit. If the soffit is greater than 2', additional design is necessary.

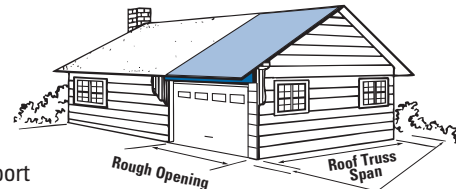

2' Soffit Assumed

Roof Loading	Rough Opening	Snow (115%)									Non-Snow (125%)								
		25 psf LL + 20 psf DL			30 psf LL + 20 psf DL			40 psf LL + 20 psf DL			20 psf LL + 15 psf DL			20 psf LL + 25 psf DL					
		9'3"	16'3"	18'3"	9'3"	16'3"	18'3"	9'3"	16'3"	18'3"	9'3"	16'3"	18'3"	9'3"	16'3"	18'3"			
Roof Truss Span with 2' Soffit Assumed	20'	1-9/8"	2-11/8"	2-14"	1-9/8"	2-14"	2-14"	1-11/8"	2-9/8"	2-14"	1-9/8"	1-14"	2-11/8"	1-9/8"	2-11/8"	2-14"	1-9/8"	2-11/8"	2-14"
	24'	1-9/8"	2-14"	2-14"	1-11/8"	2-14"	2-16"	1-11/8"	2-9/8"	2-14"	1-9/8"	2-11/8"	2-14"	1-9/8"	2-11/8"	2-14"	1-9/8"	2-14"	2-14"
	28'	1-11/8"	2-14"	2-16"	1-11/8"	2-14"	2-16"	1-11/8"	2-9/8"	2-16"	1-9/8"	2-11/8"	2-14"	1-9/8"	2-11/8"	2-14"	1-11/8"	2-9/8"	2-16"
	32'	1-11/8"	2-14"	2-16"	1-11/8"	2-16"	2-16"	1-11/8"	2-9/8"	2-16"	1-9/8"	2-14"	2-14"	1-11/8"	2-11/8"	2-14"	1-11/8"	2-9/8"	2-16"
	36'	1-11/8"	2-16"	2-16"	1-14"	2-16"	2-18"	1-11/8"	2-9/8"	3-14"	1-9/8"	2-14"	2-16"	1-11/8"	2-11/8"	2-16"	1-11/8"	2-14"	2-16"

+ See note 1.

#### NOTES:

- Required bearing length (based on 625 psi) is 3.0" unless the subscript + is shown. In that case, 4.5" is required.
- All headers require full-width bearing support, e.g., 2x6 for 5¼", 3-ply members. The adequacy of supporting columns to be verified by others.
- Deflection is limited to L/240 at live load and L/180 at total load.
- Roof live and dead loads shown are applied vertically to the horizontal projection.
- When using a single ply 1¾", consider the effect on hanger capacity, and the available bearing surface the LVL provides to other framing elements.
- A single 3/8" thick ply can be substituted for any two 1/4" thick plies.
- For multiple ply fasteners, see pages 51-53.

# 1.5E GP Lam® LVL Window and Patio Door Headers, 2-Story

## Two-Story Applications

This table shows the size (e.g.: 2-11¼" = 2 plies of 1¾" x 11¼") of beams needed to support the combined loads from a wall, second story floor (¼ of total floor joist span) and various roof truss spans with a 2' soffit. If the soffit exceeds 2', additional design is necessary.

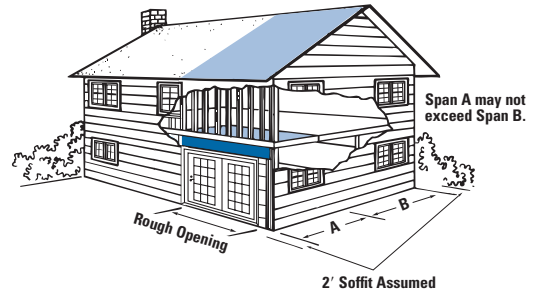

Roof Loading		Snow (115%)										Non-Snow (125%)									
		25 psf LL + 20 psf DL					40 psf LL + 20 psf DL					20 psf LL + 15 psf DL					20 psf LL + 25 psf DL				
Rough Opening		6'	8'	9'	10'	12'	6'	8'	9'	10'	12'	6'	8'	9'	10'	12'	6'	8'	9'	10'	12'
Roof Truss Span with 2' Soffit Assumed	20'	1-9/16" 2-7/16"	1-14" 2-9/16"	2-11/16" 3-9/16"	2-14" 3-11/16"	2-16" 3-14"	1-9/16" 2-7/16"	1-14" 2-11/16"	2-11/16" 3-9/16"	2-14" 3-11/16"	2-16" 3-16"	1-9/16" 2-7/16"	1-11/16" 2-9/16"	1-14" 2-11/16"	2-11/16" 3-9/16"	2-16" 3-14"	1-9/16" 2-7/16"	1-14" 2-9/16"	2-11/16" 3-9/16"	2-14" 3-11/16"	2-16" 3-14"
	24'	1-9/16" 2-7/16"	1-14" 2-11/16"	2-11/16" 3-9/16"	2-14" 3-11/16"	3-16"	1-11/16" 2-7/16"	2-11/16" 3-9/16"	2-14" 3-11/16"	2-16" 3-14"	3-16"	1-9/16" 2-7/16"	1-14" 2-9/16"	2-11/16" 3-9/16"	2-14" 3-11/16"	2-16" 3-14"	1-9/16" 2-7/16"	1-14" 2-11/16"	2-11/16" 3-9/16"	2-14" 3-11/16"	2-16" 3-16"
	28'	1-11/16" 2-7/16"	2-11/16" 3-9/16"	2-14" 3-11/16"	2-14" 3-11/16"	3-16"	1-11/16" 2-9/16"	2-11/16" 3-9/16"	2-14" 3-11/16"	2-16" 3-14"	3-16"	1-9/16" 2-7/16"	1-14" 2-11/16"	2-11/16" 3-9/16"	2-14" 3-11/16"	3-16"	1-9/16" 2-7/16"	2-11/16" 3-9/16"	2-14" 3-11/16"	2-14" 3-11/16"	2-16" 3-14"
	32'	1-11/16" 2-9/16"	2-11/16" 3-9/16"	2-14" 3-11/16"	2-16" 3-14"	3-16"	2-9/16" 3-7/16"	2-11/16" 3-9/16"	2-14" 3-11/16"	2-16" 3-14"	3-16"	1-9/16" 2-7/16"	1-14" 2-11/16"	2-11/16" 3-9/16"	2-14" 3-11/16"	3-16"	1-11/16" 2-9/16"	2-11/16" 3-9/16"	2-14" 3-11/16"	2-16" 3-14"	3-16"
	36'	1-11/16" 2-9/16"	2-11/16" 3-9/16"	2-14" 3-11/16"	2-16" 3-14"	3-16"	2-9/16" 3-7/16"	2-14" 3-11/16"	2-16" 3-14"	3-16"	3-16"	1-11/16" 2-7/16"	2-11/16" 3-9/16"	2-14" 3-11/16"	2-16" 3-14"	3-16"	1-11/16" 2-9/16"	2-11/16" 3-9/16"	2-14" 3-11/16"	2-16" 3-14"	3-16"

+ See note 1.

### NOTES:

- Required end bearing length (based on 625 psi) is 3.0" unless the subscript + is shown. In that case, 4.5" is required.
- All headers require full-width bearing support, e.g., 2x6 for 5¼", 3-ply members. The adequacy of supporting columns to be verified by others.
- Table is based on residential floor loading of 40 psf live load and 12 psf dead load and exterior wall weight of 100 plf.
- A beam line supporting the center of the second floor is assumed.
- Deflection is limited to L/360 and the lesser of L/240 or 5/16" at total load.
- Roof live and dead loads shown are applied vertically to the horizontal projection.
- When using a single ply 1¾", consider the effect on hanger capacity, and the available bearing surface the LVL provides to other framing elements.
- A single 3/2" thick ply can be substituted for any two 1¾" thick plies.
- For multiple ply fasteners, see pages 51-53.

# 1.5E GP Lam® LVL Window and Patio Door Headers, Roof Only

## Roof Applications

This table shows the size (e.g.: 2-11¼" = 2 plies of 1¾" x 11¼") of headers needed to support various roof truss spans with 2' soffit. If the soffit is greater than 2', additional design is necessary.

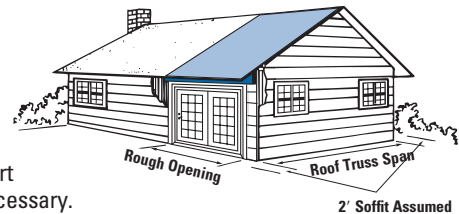

Roof Loading		Snow (115%)										Non-Snow (125%)									
		25 psf LL + 20 psf DL					40 psf LL + 20 psf DL					20 psf LL + 15 psf DL					20 psf LL + 25 psf DL				
Rough Opening		6'	8'	9'	10'	12'	6'	8'	9'	10'	12'	6'	8'	9'	10'	12'	6'	8'	9'	10'	12'
Roof Truss Span with 2' Soffit Assumed	20'	1-7/16" 2-5/16"	1-11/16" 2-9/16"	1-11/16" 2-9/16"	1-14" 2-11/16"	2-14" 3-9/16"	1-9/16" 2-7/16"	1-11/16" 2-9/16"	1-14" 2-11/16"	2-11/16" 3-9/16"	2-16" 3-14"	1-7/16" 2-5/16"	1-9/16" 2-7/16"	1-11/16" 2-9/16"	1-14" 2-11/16"	2-14" 3-11/16"	1-7/16" 2-5/16"	1-11/16" 2-9/16"	1-11/16" 2-9/16"	1-14" 2-11/16"	2-14" 3-9/16"
	24'	1-7/16" 2-9/16"	1-11/16" 3-7/16"	1-14" 3-9/16"	2-11/16" 3-9/16"	2-14"	1-9/16" 2-7/16"	1-11/16" 2-9/16"	1-14" 2-11/16"	2-14" 3-9/16"	2-16" 3-14"	1-7/16" 2-5/16"	1-11/16" 2-9/16"	1-11/16" 2-9/16"	1-14" 2-11/16"	2-14" 3-11/16"	1-7/16" 2-5/16"	1-11/16" 2-9/16"	1-14" 2-11/16"	2-11/16" 3-9/16"	2-14" 3-14"
	28'	1-9/16" 2-7/16"	1-11/16" 2-9/16"	1-14" 2-11/16"	2-11/16" 3-11/16"	2-16" 3-14"	1-9/16" 2-7/16"	1-14" 2-9/16"	2-11/16" 3-9/16"	2-14" 3-11/16"	3-16"	1-7/16" 2-5/16"	1-11/16" 2-9/16"	1-11/16" 2-9/16"	1-14" 2-11/16"	2-14" 3-11/16"	1-9/16" 2-7/16"	1-11/16" 2-9/16"	1-14" 2-11/16"	2-11/16" 3-9/16"	2-16" 3-14"
	32'	1-9/16" 2-7/16"	1-11/16" 2-9/16"	1-14" 2-11/16"	2-14" 3-11/16"	2-16" 3-14"	1-9/16" 2-7/16"	1-14" 2-11/16"	2-11/16" 3-9/16"	2-14" 3-11/16"	3-16"	1-7/16" 2-5/16"	1-11/16" 2-9/16"	1-14" 2-11/16"	2-14" 3-9/16"	3-16"	1-9/16" 2-7/16"	1-11/16" 2-9/16"	1-14" 2-11/16"	2-14" 3-11/16"	2-16" 3-14"
	36'	1-9/16" 2-7/16"	1-14" 2-9/16"	2-11/16" 3-9/16"	2-14" 3-11/16"	2-16" 3-14"	1-11/16" 2-7/16"	2-11/16" 3-9/16"	2-14" 3-11/16"	2-14"	3-16"	1-9/16" 2-7/16"	1-11/16" 2-9/16"	1-14" 2-11/16"	2-11/16" 3-9/16"	3-14"	1-9/16" 2-7/16"	1-14" 2-9/16"	2-11/16" 3-9/16"	2-14" 3-11/16"	2-16" 3-14"

+ See note 1.

### NOTES:

- Required bearing length (based on 625 psi) is 3.0" unless the subscript + is shown. In that case, 4.5" is required.
- All headers require full-width bearing support, e.g., 2x6 for 5¼", 3-ply members. The adequacy of supporting columns to be verified by others.
- Deflection is limited to L/240 at live load and the lesser of L/180 or 5/16" at total load.
- Roof live and dead loads shown are applied vertically to the horizontal projection.
- When using a single ply 1¾", consider the effect on hanger capacity, and the available bearing surface the LVL provides to other framing elements.
- A single 3/2" thick ply can be substituted for any two 1¾" thick plies.
- For multiple ply fasteners, see pages 51-53.

# GP Lam® LVL Roof Hip and Valley Beams

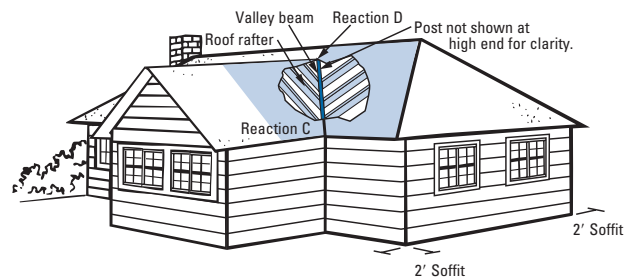
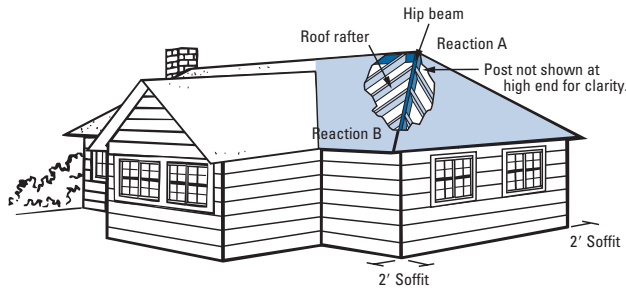

## 2.0E GP Lam LVL

		Roof Loading Snow (115%)									
		20 psf LL + 13 psf DL			30 psf LL + 13 psf DL			40 psf LL + 13 psf DL			
		Roof Slope			Roof Slope			Roof Slope			
Longest horizontal roof rafter span (L)	12'	No. of 1 3/4" plies - Beam Depth	up to 4/12	up to 8/12	up to 12/12	up to 4/12	up to 8/12	up to 12/12	up to 4/12	up to 8/12	up to 12/12
		Order Length	22'	24'	26'	22'	24'	26'	22'	24'	26'
	Max. React. A&C (lbs)	1881	2049	2326	2401	2570	2846	2921	3089	3366	
	Max. React. B&D (lbs)	1063	1155	1306	1343	1435	1586	1623	1715	1866	
	14'	No. of 1 3/4" plies - Beam Depth	1 - 1 1/4"	1 - 1 1/4"	1 - 1 1/4"	1 - 1 1/4"	1 - 1 1/4"	2 - 1 1/4"	1 - 1 1/4"	2 - 1 1/4"	2 - 1 1/4"
		Order Length	24'	26'	30'	24'	26'	30'	24'	26'	30'
	16'	No. of 1 3/4" plies - Beam Depth	2 - 1 1/4"	2 - 1 1/4"	2 - 1 1/4"	2 - 1 1/4"	2 - 1 1/4"	2 - 1 1/4"	2 - 1 1/4"	2 - 1 1/4"	2 - 1 1/4"
		Order Length	28'	30'	34'	28'	30'	34'	28'	30'	34'
	18'	No. of 1 3/4" plies - Beam Depth	2 - 1 1/4"	2 - 1 1/4"	2 - 1 1/4"	2 - 1 1/4"	2 - 1 1/4"	2 - 1 1/4"	2 - 1 1/4"	2 - 1 1/4"	2 - 1 1/4"
		Order Length	30'	32'	36'	30'	32'	36'	30'	32'	36'
20'	No. of 1 3/4" plies - Beam Depth	2 - 1 1/4"	2 - 1 1/4"	2 - 1 1/4"	2 - 1 1/4"	2 - 1 1/4"	2 - 1 1/4"	2 - 1 1/4"	2 - 1 1/4"	2 - 1 1/4"	
	Order Length	34'	36'	40'	34'	36'	40'	34'	36'	40'	
22'	No. of 1 3/4" plies - Beam Depth	2 - 1 1/4"	2 - 1 1/4"	2 - 1 1/4"	2 - 1 1/4"	2 - 1 1/4"	2 - 1 1/4"	2 - 1 1/4"	2 - 1 1/4"	2 - 1 1/4"	
	Order Length	36'	40'	44'	36'	40'	44'	36'	40'	44'	
24'	No. of 1 3/4" plies - Beam Depth	2 - 1 1/4"	2 - 1 1/4"	2 - 1 1/4"	2 - 1 1/4"	2 - 1 1/4"	2 - 1 1/4"	2 - 1 1/4"	2 - 1 1/4"	2 - 1 1/4"	
	Order Length	40'	42'	46'	40'	42'	46'	40'	42'	46'	

### NOTES:

- 2'-0" maximum roof overhang assumed.
- Provide posts or wall at both ends to support reactions. Provide 5" minimum bearing in the direction of the hip or valley at each end based on Douglas Fir-Larch or Southern Pine post or plate material. (For example, a 2x4 wall provides 5" minimum bearing for a hip or valley rafter framing at a 45 degree angle to the wall.)
- The building designer must consider thrust resistant connections at bearing locations.
- For non-equal roof slopes, use the longest horizontal roof rafter span (L) and the greatest roof slope.
- Table is based on triangular loading applied to the hip or valley member. Live load is calculated as applied vertically to the horizontal projection of the rafter and dead load is calculated along the rafter length.
- Size is based on uniform roof snow applications with a load duration factor of 115% and deflection criterion of L/240 live load and L/180 total load.
- Refer to pages 51-53 for fastening recommendations for multiple-ply members. Use the longest horizontal roof rafter span (L) to determine span-carried length for uniform loading.
- Reactions shown include heaviest beam weight selected for load and slope conditions.
- A structural ridge beam is assumed.
- A single 3/2" thick ply can be substituted for any two 1 3/4" thick plies.
- Codes require that hip and valley beam depths be greater than or equal to the cut end of the rafter.



## GP Lam® LVL Bearing Length Requirements

Reaction (lbs)	Support Material																			
	SPF South (335 psi)				Hem-Fir (405 psi)				Southern Pine (565 psi)				1.5E GP Lam LVL (750 psi)				2.0E GP Lam LVL (845 psi)			
	Beam Thickness				Beam Thickness				Beam Thickness				Beam Thickness				Beam Thickness			
	1 1/4"	3 1/2"	5 1/4"	7"	1 1/4"	3 1/2"	5 1/4"	7"	1 1/4"	3 1/2"	5 1/4"	7"	1 1/4"	3 1/2"	5 1/4"	7"	1 1/4"	3 1/2"	5 1/4"	7"
1,000	1 1/4"	1 1/2"	1 1/2"	1 1/2"	1 1/2"	1 1/2"	1 1/2"	1 1/2"	1 1/2"	1 1/2"	1 1/2"	1 1/2"	1 1/2"	1 1/2"	1 1/2"	1 1/2"	1 1/2"	1 1/2"	1 1/2"	1 1/2"
2,000	3 1/2"	1 3/4"	1 1/2"	1 1/2"	3"	1 1/2"	1 1/2"	1 1/2"	2 1/4"	1 1/2"	1 1/2"	1 1/2"	1 3/4"	1 1/2"	1 1/2"	1 1/2"	1 1/2"	1 1/2"	1 1/2"	1 1/2"
3,000	5 1/4"	2 3/4"	1 3/4"	1 1/2"	4 1/4"	2 1/4"	1 1/2"	1 1/2"	3 1/4"	1 3/4"	1 1/2"	1 1/2"	2 1/2"	1 1/2"	1 1/2"	1 1/2"	2 1/4"	1 1/2"	1 1/2"	1 1/2"
4,000	7"	3 1/2"	2 1/2"	1 3/4"	5 3/4"	3"	2"	1 1/2"	4 1/4"	2 1/4"	1 1/2"	1 1/2"	3 1/4"	1 3/4"	1 1/2"	1 1/2"	2 3/4"	1 1/2"	1 1/2"	1 1/2"
5,000	8 3/4"	4 1/2"	3"	2 1/4"	7 1/4"	3 3/4"	2 1/2"	2"	5 1/4"	2 3/4"	1 3/4"	1 1/2"	4"	2"	1 1/2"	1 1/2"	3 1/2"	1 3/4"	1 1/2"	1 1/2"
6,000	10 1/4"	5 1/4"	3 1/2"	2 3/4"	8 1/2"	4 1/4"	3"	2 1/4"	6 1/4"	3 1/4"	2 1/4"	1 3/4"	4 3/4"	2 1/2"	1 3/4"	1 1/2"	4 1/4"	2 1/4"	1 1/2"	1 1/2"
7,000		6"	4"	3"	10"	5"	3 1/2"	2 1/2"	7 1/4"	3 3/4"	2 1/2"	2"	5 1/2"	2 3/4"	2"	1 1/2"	4 3/4"	2 1/2"	1 3/4"	1 1/2"
8,000		7"	4 3/4"	3 1/2"		5 3/4"	4"	3"	8 1/4"	4 1/4"	2 3/4"	2 1/4"	6 1/4"	3 3/4"	2 1/4"	1 3/4"	5 1/2"	2 3/4"	2"	1 1/2"
9,000		7 3/4"	5 1/4"	4"		6 1/2"	4 1/4"	3 3/4"	9 1/4"	4 3/4"	3 1/4"	2 1/2"	7"	3 1/2"	2 1/2"	1 3/4"	6 1/4"	3 3/4"	2 1/4"	1 3/4"
10,000		8 3/4"	5 3/4"	4 1/2"		7 1/4"	4 3/4"	3 3/4"	10 1/4"	5 1/4"	3 1/2"	2 3/4"	7 3/4"	4"	2 3/4"	2"	7"	3 1/2"	2 1/2"	1 3/4"
11,000		9 1/2"	6 1/2"	4 3/4"		8"	5 1/4"	4"		5 3/4"	3 3/4"	3"	8 1/2"	4 1/4"	3"	2 1/4"	7 1/2"	3 3/4"	2 1/2"	2"
12,000		10 1/4"	7"	5 1/4"		8 1/2"	5 3/4"	4 1/4"		6 1/4"	4 1/4"	3 3/4"	9 1/4"	4 3/4"	3 3/4"	2 1/2"	8 1/4"	4 1/4"	2 3/4"	2 1/4"
13,000			7 1/2"	5 3/4"		9 1/4"	6 1/4"	4 3/4"		6 3/4"	4 1/2"	3 1/2"	10"	5"	3 1/2"	2 1/2"	9"	4 1/2"	3"	2 1/4"
14,000			8"	6"		10"	6 3/4"	5"		7 1/4"	4 3/4"	3 3/4"		5 1/2"	3 3/4"	2 3/4"	9 1/2"	4 1/4"	3 1/4"	2 1/2"
15,000			8 3/4"	6 1/2"			7 1/4"	5 1/2"		7 3/4"	5 1/4"	4"		5 3/4"	4"	3"	10 1/4"	5 1/4"	3 1/2"	2 3/4"
16,000			9 1/4"	7"			7 3/4"	5 3/4"		8 1/4"	5 1/2"	4 1/4"		6 1/4"	4 1/4"	3 3/4"		5 1/2"	3 3/4"	2 3/4"
17,000			9 3/4"	7 1/4"			8"	6"		8 3/4"	5 3/4"	4 1/2"		6 1/2"	4 1/2"	3 3/4"		5 3/4"	4"	3"
18,000			10 1/4"	7 3/4"			8 1/2"	6 1/2"		9 1/4"	6 1/4"	4 3/4"		7"	4 3/4"	3 1/2"		6 1/4"	4 1/4"	3 1/4"
19,000				8 1/4"			9"	6 3/4"		9 3/4"	6 1/2"	5"		7 1/4"	5"	3 3/4"		6 1/2"	4 1/2"	3 1/4"
20,000				8 3/4"			9 1/2"	7 1/4"		10 1/4"	6 3/4"	5 1/4"		7 3/4"	5 1/4"	4"		7"	4 3/4"	3 1/2"
21,000				9"			10"	7 1/2"			7 1/4"	5 1/2"		8"	5 1/2"	4"		7 1/4"	4 3/4"	3 3/4"
22,000				9 1/2"			10 1/2"	8"			7 1/2"	5 3/4"		8 1/2"	5 3/4"	4 1/4"		7 1/2"	5"	3 3/4"
23,000				10"				8 1/4"			8"	6"		9"	6"	4 1/2"		8"	5 1/4"	4"
24,000				10 1/4"				8 1/2"			8 1/4"	6 1/4"		9 1/4"	6 1/4"	4 3/4"		8 1/4"	5 1/2"	4 1/4"
25,000								9"			8 1/2"	6 1/2"		9 3/4"	6 1/2"	5"		8 1/2"	5 3/4"	4 1/4"

### NOTES:

- Minimum required bearing length is 1 1/2" for end bearings and 3" for intermediate bearings.
- Bearing across full width of beam or header is required.
- Table is based on moisture content being less than 16% for engineered lumber and not exceeding 19% for lumber.
- Confirmation of structural adequacy of supporting member is required.
- GP Lam LVL beams and headers must be restrained against rotation at ends and supports.
- When plate material is of **Southern Pine graded non-dense** or of **SPF**, use bearing lengths shown for Hem-Fir .
- When plate material is of **Douglas Fir-Larch** or **Douglas Fir-Larch (N)**, use bearing lengths shown for Southern Pine.
- When GP Lam LVL rests **on steel or in a hanger**, use bearing lengths shown for respective GP Lam LVL.
- When GP Lam LVL rests directly **on end grain of studs or cripples** of the lumber listed above, use bearing lengths shown for 1.5E GP Lam LVL multiplied by 1.2.
- No reduction in bearing length (no increase in bearing stress,  $F_{\perp}$ ) is allowed for duration of load.

## Allowable Horizontal Holes in GP Lam<sup>®</sup> LVL

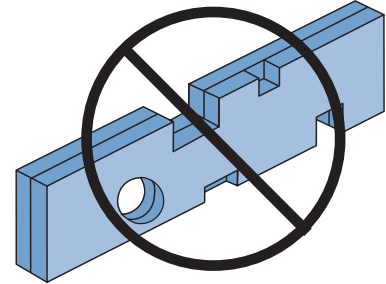
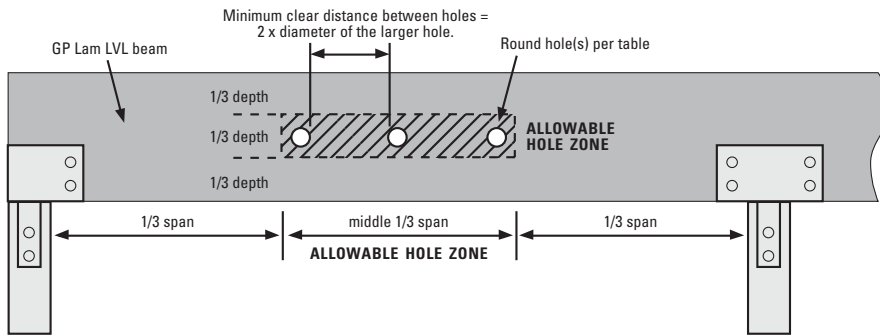

Do not notch, drill or cut GP Lam LVL except as shown in this publication.

### NOTES:

- Hole(s) must be located completely in the allowable hole zone.
- No rectangular holes are allowed.
- No more than three holes allowed per span.
- Table is valid for single and multiple span uniformly loaded beams only. Table is not valid for cantilever sections.
- Hole location, clearance and the effects of beam deflection should be considered to avoid problems with piping.

Allowable Hole Sizes

Beam Depth	Maximum Round Hole Diameter
3½"-7"	¾"
7¼"-9¼"	1½"
9½"-16"	2"
deeper than 16"	3"

## Using Allowable Uniform Floor and Roof Load Tables (Pages 42-50)

- Tables are based on uniform loads, the more restrictive of simple or continuous spans (measured center-to-center), and dry-use conditions (moisture content less than 16%). Loads shown can be applied to the beam in addition to its own weight. For other loads or span configurations, use FASTBeam<sup>®</sup> analysis and selection software or contact your Georgia-Pacific representative.
- Beam thickness is the net thickness of the beam. A single 3½" thick ply can be substituted for any two 1¾" thick plies. See pages 51-53 for multiple-ply member connection details.
- To size a beam it is necessary to check both live load and total load. Selected beam must work in both rows. When no live load is shown, total load will control, unless floor live load deflections other than L/360 are checked per note 4.
- For floor live load deflection limits of L/480 or L/600, multiply the value in the floor 'LL' row (or 'TL' when 'LL' is not shown) by 0.75 or 0.60 respectively.
- To size a member for a span not shown, use capacities for the next larger span shown (example: for 7' span, use values shown for 8' span).
- Verify deflection limits with local building code requirements.
- Bearing across full width of beam is assumed.
- Assumes 565 psi bearing stress limited by Douglas Fir, Southern Yellow Pine or other dense supporting material. For SPF or other less dense materials, either double the bearing length shown or refer to Bearing Length Requirements on page 40.
- Bearing length may be adjusted if a beam is not fully loaded. For example, if 4.2" of bearing is required for a beam with maximum total load capacity of 1000 PLF yet the total design load is only 700 PLF the bearing length may be adjusted as follows:  $700/1000 \times 4.2 = 2.94"$  minimum (use 2 cripples for 3"). In no case may end bearing length be less than 1½" or intermediate bearing length less than 3".
- Provide lateral support at bearing points, and continuous lateral support along the top (or compression edge) of beam.
- 1¾" thick beams with depth greater than 14" must only be used in multiple-ply members.
- For 3-ply 1¾" (5¼") or 4-ply 1¾" (7") GP Lam LVL, use 1¾" table and multiply by 3 or 4 respectively.
- Roof surface must slope a minimum of ¼/12 or as required for drainage.

### EXAMPLE:

Select a 2.0E GP Lam LVL beam to carry 520 PLF live load + 200 PLF dead load. Beam supports both floor and roof, and spans 10'.

When a beam carries floor and roof, use tables for floor loads; these tables are based on more stringent criteria than those used for roof loads. Use the table titled Floor 100%, on pages 42-43. Adding 520 PLF and 200 PLF gives a total load of 720 PLF. Find 10' in the left-most column. To the right are three rows showing Live Load L/360, Total Load and Minimum End and Minimum Interior Bearing requirements in inches. In the row marked Total Load, move to the right to locate a total load of at least 720 PLF. 1¾" x 11½" GP Lam LVL Beam can carry 745 PLF total load. Check live load capacity. 1¾" x 11½" can carry 629 PLF live load, so live load capacity is also adequate. Note required end bearing length is 3.8" and 9.5" for interior bearing of multiple spans. (See Note 9 above)

If less bearing length or a depth less than 11½" is desired, check the capacity of 3½" LVL beams. In the row marked Total Load, move farther to the right to locate a total load of at least 720 PLF. A 3½" wide x 9¼" deep member can carry 931 PLF total load. Check that live load capacity is at least 520 PLF. 3½" x 9¼" beams can carry 627 PLF, which is sufficient. Use 3½" x 9¼" deep. Required end bearing is 2.4" and 5.9" is required for interior bearing of multiple spans.

## Allowable Uniform Floor Loads (PLF) – 100%

(Can be applied to the beam in addition to its own weight.)

### 2.0E GP Lam® LVL

Span	Condition	One 1 1/4" GP Lam LVL						Two 1 1/4" GP Lam LVL								
		7 1/4"	9 1/4"	9 1/2"	11 1/4"	11 1/2"	14"	7 1/4"	9 1/4"	9 1/2"	11 1/4"	11 1/2"	14"	16"	18"	24"
6'	Live Load L/360	660						1319								
	Total Load	763	1028	1063	1325	1425	1575	1526	2056	2126	2649	2849	3151	3149	3147	3141
	End / Int. Bearing	2.3 / 5.8	3.1 / 7.8	3.2 / 8.1	4.0 / 10.1	4.3 / 10.8	4.8 / 12.0	2.3 / 5.8	3.1 / 7.8	3.2 / 8.1	4.0 / 10.1	4.3 / 10.8	4.8 / 12.0	4.8 / 12.0	4.8 / 12.0	4.8 / 12.0
8'	Live Load L/360	296	585	629				591	1169	1258						
	Total Load	440	723	746	915	979	1180	880	1446	1492	1831	1958	2360	2358	2356	2350
	End / Int. Bearing	1.8 / 4.5	2.9 / 7.4	3.0 / 7.6	3.7 / 9.3	4.0 / 10.0	4.8 / 12.0	1.8 / 4.5	2.9 / 7.4	3.0 / 7.6	3.7 / 9.3	4.0 / 10.0	4.8 / 12.0	4.8 / 12.0	4.8 / 12.0	4.8 / 12.0
10'	Live Load L/360	156	313	338	542	629		312	627	676	1084	1258				
	Total Load	230	466	502	699	745	909	461	931	1005	1398	1490	1818	1883	1881	1876
	End / Int. Bearing	1.5 / 3.0	2.4 / 5.9	2.6 / 6.4	3.6 / 8.9	3.8 / 9.5	4.6 / 11.6	1.5 / 3.0	2.4 / 5.9	2.6 / 6.4	3.6 / 8.9	3.8 / 9.5	4.6 / 11.6	4.8 / 12.0	4.8 / 12.0	4.8 / 12.0
11'	Live Load L/360	118	239	258	416	484		236	478	516	832	967	1519			
	Total Load	174	354	382	589	652	809	348	708	764	1177	1305	1618	1711	1709	1703
	End / Int. Bearing	1.5 / 3.0	2.0 / 5.0	2.2 / 5.4	3.3 / 8.3	3.7 / 9.1	4.5 / 11.3	1.5 / 3.0	2.0 / 5.0	2.2 / 5.4	3.3 / 8.3	3.7 / 9.1	4.5 / 11.3	4.8 / 12.0	4.8 / 12.0	4.8 / 12.0
12'	Live Load L/360	91	186	201	325	379		183	372	402	651	758	1198			
	Total Load	134	275	297	483	547	728	268	550	594	966	1094	1457	1567	1565	1559
	End / Int. Bearing	1.5 / 3.0	1.7 / 4.2	1.8 / 4.6	3.0 / 7.4	3.4 / 8.4	4.5 / 11.2	1.5 / 3.0	1.7 / 4.2	1.8 / 4.6	3.0 / 7.4	3.4 / 8.4	4.5 / 11.2	4.8 / 12.0	4.8 / 12.0	4.8 / 12.0
13'	Live Load L/360	72	147	159	259	302		145	295	319	519	605	961	1387		
	Total Load	105	217	235	384	448	636	211	434	470	767	896	1272	1445	1443	1438
	End / Int. Bearing	1.5 / 3.0	1.5 / 3.6	1.6 / 3.9	2.6 / 6.4	3.0 / 7.5	4.2 / 10.6	1.5 / 3.0	1.5 / 3.6	1.6 / 3.9	2.6 / 6.4	3.0 / 7.5	4.2 / 10.6	4.8 / 12.0	4.8 / 12.0	4.8 / 12.0
14'	Live Load L/360	58	119	128	210	245		116	238	257	420	490	781	1132		
	Total Load	84	174	188	309	362	548	168	348	377	619	723	1095	1341	1339	1333
	End / Int. Bearing	1.5 / 3.0	1.5 / 3.2	1.5 / 3.4	2.2 / 5.6	2.6 / 6.5	3.9 / 9.8	1.5 / 3.0	1.5 / 3.2	1.5 / 3.4	2.2 / 5.6	2.6 / 6.5	3.9 / 9.8	4.8 / 12.0	4.8 / 12.0	4.8 / 12.0
15'	Live Load L/360	47	97	105	172	201		95	195	210	344	402	643	935		
	Total Load	68	141	153	253	296	476	136	283	307	505	592	951	1228	1249	1243
	End / Int. Bearing	1.5 / 3.0	1.5 / 3.0	1.5 / 3.0	2.0 / 4.9	2.3 / 5.7	3.7 / 9.1	1.5 / 3.0	1.5 / 3.0	1.5 / 3.0	2.0 / 4.9	2.3 / 5.7	3.7 / 9.1	4.7 / 11.8	4.8 / 12.0	4.8 / 12.0
16'	Live Load L/360		80	87	142	167		78	161	174	285	334	535	781		
	Total Load		116	126	209	245	395	111	233	253	417	489	790	1077	1169	1164
	End / Int. Bearing		1.5 / 3.0	1.5 / 3.0	1.7 / 4.3	2.0 / 5.1	3.2 / 8.1	1.5 / 3.0	1.5 / 3.0	1.5 / 3.0	1.7 / 4.3	2.0 / 5.1	3.2 / 8.1	4.4 / 11.0	4.8 / 12.0	4.8 / 12.0
17'	Live Load L/360		67	73	119	140		65	135	146	239	280	450	658	916	
	Total Load		97	105	174	204	331	91	194	210	348	409	662	952	1100	1094
	End / Int. Bearing		1.5 / 3.0	1.5 / 3.0	1.5 / 3.9	1.8 / 4.5	2.9 / 7.3	1.5 / 3.0	1.5 / 3.0	1.5 / 3.0	1.5 / 3.9	1.8 / 4.5	2.9 / 7.3	4.2 / 10.4	4.8 / 12.0	4.8 / 12.0
18'	Live Load L/360		57	61	101	118		55	114	123	202	237	382	560	781	
	Total Load		81	88	146	172	280	76	162	176	293	344	560	824	1038	1032
	End / Int. Bearing		1.5 / 3.0	1.5 / 3.0	1.5 / 3.5	1.6 / 4.0	2.6 / 6.5	1.5 / 3.0	1.5 / 3.0	1.5 / 3.0	1.5 / 3.5	1.6 / 4.0	2.6 / 6.5	3.8 / 9.6	4.8 / 12.0	4.8 / 12.0
19'	Live Load L/360		48	52	86	101		47	97	105	173	202	327	480	671	
	Total Load		68	74	124	146	238	64	137	149	249	293	477	705	951	976
	End / Int. Bearing		1.5 / 3.0	1.5 / 3.0	1.5 / 3.1	1.5 / 3.6	2.4 / 5.9	1.5 / 3.0	1.5 / 3.0	1.5 / 3.0	1.5 / 3.1	1.5 / 3.6	2.4 / 5.9	3.5 / 8.6	4.6 / 11.6	4.8 / 12.0
20'	Live Load L/360		41	45	74	87		40	83	90	148	174	282	414	580	
	Total Load		58	63	106	125	205	54	116	126	212	250	409	606	853	926
	End / Int. Bearing		1.5 / 3.0	1.5 / 3.0	1.5 / 3.0	1.5 / 3.3	2.1 / 5.3	1.5 / 3.0	1.5 / 3.0	1.5 / 3.0	1.5 / 3.0	1.5 / 3.0	1.5 / 3.3	2.1 / 5.3	3.1 / 7.9	4.4 / 11.0
22'	Live Load L/360				56	65			63	68	112	131	213	315	442	
	Total Load				79	93	153		85	93	158	186	307	457	646	840
	End / Int. Bearing				1.5 / 3.0	1.5 / 3.0	1.8 / 4.5		1.5 / 3.0	1.5 / 3.0	1.5 / 3.0	1.5 / 3.0	1.5 / 3.0	1.8 / 4.5	2.6 / 6.6	3.7 / 9.2
24'	Live Load L/360				43	51			48	52	87	102	165	244	344	
	Total Load				60	71	117		64	70	120	142	235	352	499	768
	End / Int. Bearing				1.5 / 3.0	1.5 / 3.0	1.5 / 3.8		1.5 / 3.0	1.5 / 3.0	1.5 / 3.0	1.5 / 3.0	1.5 / 3.8	2.2 / 5.6	3.1 / 7.8	4.8 / 12.0
26'	Live Load L/360					40				41	68	80	131	193	273	623
	Total Load					54	91			53	92	109	183	275	392	707
	End / Int. Bearing					1.5 / 3.0	1.5 / 3.2			1.5 / 3.0	1.5 / 3.0	1.5 / 3.0	1.5 / 3.2	1.9 / 4.8	2.7 / 6.7	4.8 / 12.0
28'	Live Load L/360						52				55	64	105	156	220	505
	Total Load						72				72	85	144	219	313	655
	End / Int. Bearing						1.5 / 3.0				1.5 / 3.0	1.5 / 3.0	1.5 / 3.0	1.7 / 4.1	2.3 / 5.8	4.8 / 12.0

#### KEY TO TABLES

**Live Load L/360** = Maximum live load — limits deflection to L/360

**Total Load** = Maximum total load — limits deflection to L/240

**End / Int. Bearing** = Required minimum end bearing (inches) for simple or multiple span beams and minimum interior bearing (inches) for multiple span beams based on plate bearing stress of 565 psi.

See "Using Allowable Uniform Floor and Roof Load Tables," page 41.

# Allowable Uniform Floor Loads (PLF) – 100%

(Can be applied to the beam in addition to its own weight.)

## 2.0E GP Lam® LVL

Span	Condition	Three 1 3/4" GP Lam LVL								Four 1 3/4" GP Lam LVL							
		9 1/4"	9 1/2"	11 1/4"	11 1/2"	14"	16"	18"	24"	9 1/4"	9 1/2"	11 1/4"	11 1/2"	14"	16"	18"	24"
6'	Live Load L/360	3084	3190	3974	4274	4726	4723	4720	4712	4112	4253	5299	5699	6301	6298	6294	6283
	Total Load	3.1 / 7.8	3.2 / 8.1	4.0 / 10.1	4.3 / 10.8	4.8 / 12.0	4.8 / 12.0	4.8 / 12.0	4.8 / 12.0	3.1 / 7.8	3.2 / 8.1	4.0 / 10.1	4.3 / 10.8	4.8 / 12.0	4.8 / 12.0	4.8 / 12.0	4.8 / 12.0
8'	Live Load L/360	1754	1887	2746	2937	3540	3537	3534	3525	2338	2516	3662	3916	4719	4716	4712	4701
	Total Load	2.9 / 7.4	3.0 / 7.6	3.7 / 9.3	4.0 / 10.0	4.8 / 12.0	4.8 / 12.0	4.8 / 12.0	4.8 / 12.0	2.9 / 7.4	3.0 / 7.6	3.7 / 9.3	4.0 / 10.0	4.8 / 12.0	4.8 / 12.0	4.8 / 12.0	4.8 / 12.0
10'	Live Load L/360	940	1014	1626	1887	2279	2825	2822	2813	1254	1352	2168	2516	3038	3766	3763	3751
	Total Load	2.4 / 5.9	2.6 / 6.4	3.6 / 8.9	3.8 / 9.5	4.6 / 11.6	4.8 / 12.0	4.8 / 12.0	4.8 / 12.0	2.4 / 5.9	2.6 / 6.4	3.6 / 8.9	3.8 / 9.5	4.6 / 11.6	4.8 / 12.0	4.8 / 12.0	4.8 / 12.0
11'	Live Load L/360	717	773	1248	1451	2279	2566	2563	2555	956	1031	1663	1934	3038	3421	3418	3406
	Total Load	2.0 / 5.0	2.2 / 5.4	3.3 / 8.3	3.7 / 9.1	4.5 / 11.3	4.8 / 12.0	4.8 / 12.0	4.8 / 12.0	2.0 / 5.0	2.2 / 5.4	3.3 / 8.3	3.7 / 9.1	4.5 / 11.3	4.8 / 12.0	4.8 / 12.0	4.8 / 12.0
12'	Live Load L/360	558	603	977	1137	1798	2279	2347	2339	744	804	1302	1517	2397	3134	3130	3119
	Total Load	1.7 / 4.2	1.8 / 4.6	3.0 / 7.4	3.4 / 8.4	4.5 / 11.2	4.8 / 12.0	4.8 / 12.0	4.8 / 12.0	1.7 / 4.2	1.8 / 4.6	3.0 / 7.4	3.4 / 8.4	4.5 / 11.2	4.8 / 12.0	4.8 / 12.0	4.8 / 12.0
13'	Live Load L/360	443	479	778	907	1441	2081	2165	2156	591	638	1037	1210	1921	2774	2886	2875
	Total Load	1.5 / 3.6	1.6 / 3.9	2.6 / 6.4	3.0 / 7.5	4.2 / 10.6	4.8 / 12.0	4.8 / 12.0	4.8 / 12.0	1.5 / 3.6	1.6 / 3.9	2.6 / 6.4	3.0 / 7.5	4.2 / 10.6	4.8 / 12.0	4.8 / 12.0	4.8 / 12.0
14'	Live Load L/360	357	386	629	735	1171	1698	2008	2000	476	515	839	980	1562	2265	2678	2667
	Total Load	1.5 / 3.2	1.5 / 3.4	2.2 / 5.6	2.6 / 6.5	3.9 / 9.8	4.8 / 12.0	4.8 / 12.0	4.8 / 12.0	1.5 / 3.2	1.5 / 3.4	2.2 / 5.6	2.6 / 6.5	3.9 / 9.8	4.8 / 12.0	4.8 / 12.0	4.8 / 12.0
15'	Live Load L/360	292	316	516	603	964	1403	1873	1864	390	421	688	804	1286	1871	2497	2486
	Total Load	1.5 / 3.0	1.5 / 3.0	2.0 / 4.9	2.3 / 5.7	3.7 / 9.1	4.7 / 11.8	4.8 / 12.0	4.8 / 12.0	1.5 / 3.0	1.5 / 3.0	2.0 / 4.9	2.3 / 5.7	3.7 / 9.1	4.7 / 11.8	4.8 / 12.0	4.8 / 12.0
16'	Live Load L/360	242	261	428	501	803	1171	1626	1746	322	349	571	667	1070	1562	2168	2328
	Total Load	1.5 / 3.0	1.5 / 3.0	1.7 / 4.3	2.0 / 5.1	3.2 / 8.1	4.4 / 11.0	4.8 / 12.0	4.8 / 12.0	1.5 / 3.0	1.5 / 3.0	1.7 / 4.3	2.0 / 5.1	3.2 / 8.1	4.4 / 11.0	4.8 / 12.0	4.8 / 12.0
17'	Live Load L/360	202	219	359	420	675	987	1374	1641	270	292	479	560	900	1317	1833	2188
	Total Load	1.5 / 3.0	1.5 / 3.0	1.5 / 3.9	1.8 / 4.5	2.9 / 7.3	4.2 / 10.4	4.8 / 12.0	4.8 / 12.0	1.5 / 3.0	1.5 / 3.0	1.5 / 3.9	1.8 / 4.5	2.9 / 7.3	4.2 / 10.4	4.8 / 12.0	4.8 / 12.0
18'	Live Load L/360	171	185	304	356	573	840	1171	1548	228	247	405	474	764	1120	1562	2064
	Total Load	1.5 / 3.0	1.5 / 3.0	1.5 / 3.5	1.6 / 4.0	2.6 / 6.5	3.8 / 9.6	4.8 / 12.0	4.8 / 12.0	1.5 / 3.0	1.5 / 3.0	1.5 / 3.5	1.6 / 4.0	2.6 / 6.5	3.8 / 9.6	4.8 / 12.0	4.8 / 12.0
19'	Live Load L/360	146	158	259	304	490	720	1006	1465	194	210	346	405	654	960	1341	1953
	Total Load	1.5 / 3.0	1.5 / 3.0	1.5 / 3.1	1.5 / 3.6	2.4 / 5.9	3.5 / 8.6	4.6 / 11.6	4.8 / 12.0	1.5 / 3.0	1.5 / 3.0	1.5 / 3.1	1.5 / 3.6	2.4 / 5.9	3.5 / 8.6	4.6 / 11.6	4.8 / 12.0
20'	Live Load L/360	125	135	223	261	423	621	870	1390	167	181	297	349	563	828	1160	1853
	Total Load	1.5 / 3.0	1.5 / 3.0	1.5 / 3.0	1.5 / 3.3	2.1 / 5.3	3.1 / 7.9	4.4 / 11.0	4.8 / 12.0	1.5 / 3.0	1.5 / 3.0	1.5 / 3.0	1.5 / 3.3	2.1 / 5.3	3.1 / 7.9	4.4 / 11.0	4.8 / 12.0
22'	Live Load L/360	94	102	168	197	320	472	663	1260	126	136	225	263	427	629	884	1680
	Total Load	1.5 / 3.0	1.5 / 3.0	1.5 / 3.0	1.5 / 3.0	1.8 / 4.5	2.6 / 6.6	3.7 / 9.2	4.8 / 12.0	1.5 / 3.0	1.5 / 3.0	1.5 / 3.0	1.5 / 3.0	1.8 / 4.5	2.6 / 6.6	3.7 / 9.2	4.8 / 12.0
24'	Live Load L/360	73	79	130	153	248	367	516	1152	97	105	174	204	331	489	688	1537
	Total Load	1.5 / 3.0	1.5 / 3.0	1.5 / 3.0	1.5 / 3.0	1.5 / 3.8	2.2 / 5.6	3.1 / 7.8	4.8 / 12.0	1.5 / 3.0	1.5 / 3.0	1.5 / 3.0	1.5 / 3.0	1.5 / 3.8	2.2 / 5.6	3.1 / 7.8	4.8 / 12.0
26'	Live Load L/360	57	62	103	120	196	290	409	935	76	83	137	161	262	387	546	1246
	Total Load	1.5 / 3.0	1.5 / 3.0	1.5 / 3.0	1.5 / 3.0	1.5 / 3.2	1.9 / 4.8	2.7 / 6.7	4.8 / 12.0	1.5 / 3.0	1.5 / 3.0	1.5 / 3.0	1.5 / 3.0	1.5 / 3.2	1.9 / 4.8	2.7 / 6.7	4.8 / 12.0
28'	Live Load L/360	46	50	82	97	158	234	330	757	61	66	110	129	210	312	440	1009
	Total Load	1.5 / 3.0	1.5 / 3.0	1.5 / 3.0	1.5 / 3.0	1.5 / 3.0	1.7 / 4.1	2.3 / 5.8	4.8 / 12.0	1.5 / 3.0	1.5 / 3.0	1.5 / 3.0	1.5 / 3.0	1.5 / 3.0	1.7 / 4.1	2.3 / 5.8	4.8 / 12.0

### KEY TO TABLES

**Live Load L/360** = Maximum live load — limits deflection to L/360

**Total Load** = Maximum total load — limits deflection to L/240

**End/Int. Bearing** = Required minimum end bearing (inches) for simple or multiple span beams and minimum interior bearing (inches) for multiple span beams based on plate bearing stress of 565 psi.

See "Using Allowable Uniform Floor and Roof Load Tables," page 41.

# Allowable Uniform Roof Loads (PLF) – 115% (Snow)

(Can be applied to the beam in addition to its own weight.)

## 2.0E GP Lam® LVL

Span	Condition	One 1 1/4" GP Lam LVL						Two 1 1/4" GP Lam LVL								
		7 1/4"	9 1/4"	9 1/2"	11 1/4"	11 1/8"	14"	7 1/4"	9 1/4"	9 1/2"	11 1/4"	11 1/8"	14"	16"	18"	24"
6'	Live Load L/240															
	Total Load	878	1183	1223	1524	1576	1575	1756	2366	2447	3048	3153	3151	3149	3147	3141
	End / Int. Bearing	2.7 / 6.7	3.6 / 9.0	3.7 / 9.3	4.6 / 11.6	4.8 / 12.0	4.8 / 12.0	2.7 / 6.7	3.6 / 9.0	3.7 / 9.3	4.6 / 11.6	4.8 / 12.0	4.8 / 12.0	4.8 / 12.0	4.8 / 12.0	4.8 / 12.0
8'	Live Load L/240	444						887								
	Total Load	560	832	859	1054	1127	1180	1120	1664	1717	2107	2253	2360	2358	2356	2350
	End / Int. Bearing	2.3 / 5.7	3.4 / 8.5	3.5 / 8.7	4.3 / 10.7	4.6 / 11.5	4.8 / 12.0	2.3 / 5.7	3.4 / 8.5	3.5 / 8.7	4.3 / 10.7	4.6 / 11.5	4.8 / 12.0	4.8 / 12.0	4.8 / 12.0	4.8 / 12.0
10'	Live Load L/240	234	470	507				468	940	1014						
	Total Load	308	567	596	804	858	943	617	1133	1192	1609	1715	1885	1883	1881	1876
	End / Int. Bearing	1.6 / 3.9	2.9 / 7.2	3.0 / 7.6	4.1 / 10.2	4.4 / 10.9	4.8 / 12.0	1.6 / 3.9	2.9 / 7.2	3.0 / 7.6	4.1 / 10.2	4.4 / 10.9	4.8 / 12.0	4.8 / 12.0	4.8 / 12.0	4.8 / 12.0
11'	Live Load L/240	177	358	387	624	725		355	717	773	1248	1451				
	Total Load	233	468	492	678	751	856	466	935	984	1356	1502	1713	1711	1709	1703
	End / Int. Bearing	1.5 / 3.3	2.6 / 6.6	2.8 / 6.9	3.8 / 9.5	4.2 / 10.5	4.8 / 12.0	1.5 / 3.3	2.6 / 6.6	2.8 / 6.9	3.8 / 9.5	4.2 / 10.5	4.8 / 12.0	4.8 / 12.0	4.8 / 12.0	4.8 / 12.0
12'	Live Load L/240	137	279	301	488	569		275	558	603	977	1137				
	Total Load	180	368	397	569	630	784	360	736	795	1137	1260	1569	1567	1565	1559
	End / Int. Bearing	1.5 / 3.0	2.3 / 5.6	2.4 / 6.1	3.5 / 8.7	3.9 / 9.6	4.8 / 12.0	1.5 / 3.0	2.3 / 5.6	2.4 / 6.1	3.5 / 8.7	3.9 / 9.6	4.8 / 12.0	4.8 / 12.0	4.8 / 12.0	4.8 / 12.0
13'	Live Load L/240	109	221	239	389	454	720	218	443	479	778	907	1441			
	Total Load	142	291	315	484	536	724	283	582	629	968	1072	1447	1445	1443	1438
	End / Int. Bearing	1.5 / 3.0	1.9 / 4.9	2.1 / 5.2	3.2 / 8.0	3.6 / 8.9	4.8 / 12.0	1.5 / 3.0	1.9 / 4.9	2.1 / 5.2	3.2 / 8.0	3.6 / 8.9	4.8 / 12.0	4.8 / 12.0	4.8 / 12.0	4.8 / 12.0
14'	Live Load L/240	87	179	193	315	367	586	175	357	386	629	735	1171			
	Total Load	113	234	253	414	461	631	226	468	506	828	923	1262	1341	1339	1333
	End / Int. Bearing	1.5 / 3.0	1.7 / 4.2	1.8 / 4.6	3.0 / 7.4	3.3 / 8.3	4.5 / 11.3	1.5 / 3.0	1.7 / 4.2	1.8 / 4.6	3.0 / 7.4	3.3 / 8.3	4.5 / 11.3	4.8 / 12.0	4.8 / 12.0	4.8 / 12.0
15'	Live Load L/240	71	146	158	258	301	482	143	292	316	516	603	964			
	Total Load	92	190	206	339	396	549	184	381	412	677	793	1097	1250	1249	1243
	End / Int. Bearing	1.5 / 3.0	1.5 / 3.7	1.6 / 4.0	2.6 / 6.5	3.0 / 7.6	4.2 / 10.5	1.5 / 3.0	1.5 / 3.7	1.6 / 4.0	2.6 / 6.5	3.0 / 7.6	4.2 / 10.5	4.8 / 12.0	4.8 / 12.0	4.8 / 12.0
16'	Live Load L/240	59	121	131	214	250	401	118	242	262	428	501	803			
	Total Load	75	157	170	280	328	481	150	314	340	560	656	963	1171	1169	1164
	End / Int. Bearing	1.5 / 3.0	1.5 / 3.3	1.5 / 3.5	2.3 / 5.8	2.7 / 6.7	3.9 / 9.9	1.5 / 3.0	1.5 / 3.3	1.5 / 3.5	2.3 / 5.8	2.7 / 6.7	3.9 / 9.9	4.8 / 12.0	4.8 / 12.0	4.8 / 12.0
17'	Live Load L/240	49	101	109	179	210	338	98	202	219	359	420	675	987		
	Total Load	62	130	141	234	274	426	124	261	283	468	549	851	1098	1100	1094
	End / Int. Bearing	1.5 / 3.0	1.5 / 3.0	1.5 / 3.1	2.1 / 5.1	2.4 / 6.0	3.7 / 9.3	1.5 / 3.0	1.5 / 3.0	1.5 / 3.1	2.1 / 5.1	2.4 / 6.0	3.7 / 9.3	4.8 / 12.0	4.8 / 12.0	4.8 / 12.0
18'	Live Load L/240	41	85	92	152	178	286	83	171	185	304	356	573	840		
	Total Load	52	109	119	197	232	375	104	219	238	394	463	751	977	1038	1032
	End / Int. Bearing	1.5 / 3.0	1.5 / 3.0	1.5 / 3.0	1.8 / 4.6	2.2 / 5.4	3.5 / 8.7	1.5 / 3.0	1.5 / 3.0	1.5 / 3.0	1.8 / 4.6	2.2 / 5.4	3.5 / 8.7	4.5 / 11.3	4.8 / 12.0	4.8 / 12.0
19'	Live Load L/240		73	79	129	152	245	71	146	158	259	304	490	720		
	Total Load		93	100	168	197	320	87	186	201	335	394	640	876	982	976
	End / Int. Bearing		1.5 / 3.0	1.5 / 3.0	1.7 / 4.2	1.9 / 4.9	3.1 / 7.8	1.5 / 3.0	1.5 / 3.0	1.5 / 3.0	1.7 / 4.2	1.9 / 4.9	3.1 / 7.8	4.3 / 10.7	4.8 / 12.0	4.8 / 12.0
20'	Live Load L/240		62	67	111	131	211	61	125	135	223	262	423	621	870	
	Total Load		79	86	143	169	275	74	158	172	287	337	550	789	932	926
	End / Int. Bearing		1.5 / 3.0	1.5 / 3.0	1.5 / 3.8	1.8 / 4.4	2.8 / 7.1	1.5 / 3.0	1.5 / 3.0	1.5 / 3.0	1.5 / 3.8	1.8 / 4.4	2.8 / 7.1	4.1 / 10.2	4.8 / 12.0	4.8 / 12.0
22'	Live Load L/240		47	51	84	99	160	45	94	102	168	198	320	472	663	
	Total Load		58	63	107	126	207	54	117	127	214	252	414	614	813	840
	End / Int. Bearing		1.5 / 3.0	1.5 / 3.0	1.5 / 3.1	1.5 / 3.7	2.4 / 5.9	1.5 / 3.0	1.5 / 3.0	1.5 / 3.0	1.5 / 3.1	1.5 / 3.7	2.4 / 5.9	3.5 / 8.8	4.6 / 11.5	4.8 / 12.0
24'	Live Load L/240			39	65	76	124		73	79	130	153	248	367	516	
	Total Load			48	81	96	159		88	96	163	193	318	474	671	768
	End / Int. Bearing			1.5 / 3.0	1.5 / 3.0	1.5 / 3.1	2.0 / 5.0		1.5 / 3.0	1.5 / 3.0	1.5 / 3.0	1.5 / 3.1	2.0 / 5.0	3.0 / 7.4	4.2 / 10.4	4.8 / 12.0
26'	Live Load L/240				51	60	98		57	62	103	121	196	290	409	
	Total Load				63	75	124		68	74	126	150	248	372	529	707
	End / Int. Bearing				1.5 / 3.0	1.5 / 3.0	1.7 / 4.3		1.5 / 3.0	1.5 / 3.0	1.5 / 3.0	1.5 / 3.0	1.7 / 4.3	2.5 / 6.4	3.6 / 9.0	4.8 / 12.0
28'	Live Load L/240				41	48	79		46	50	82	97	158	234	330	
	Total Load				49	59	98		52	57	99	118	197	296	423	655
	End / Int. Bearing				1.5 / 3.0	1.5 / 3.0	1.5 / 3.7		1.5 / 3.0	1.5 / 3.0	1.5 / 3.0	1.5 / 3.0	1.5 / 3.7	2.2 / 5.5	3.1 / 7.8	4.8 / 12.0

### KEY TO TABLES

**Live Load L/240** = Maximum live load — limits deflection to L/240

**Total Load** = Maximum total load — limits deflection to L/180

**End / Int. Bearing** = Required minimum end bearing (inches) for simple or multiple span beams and minimum interior bearing (inches) for multiple span beams based on plate bearing stress of 565 psi.

See "Using Allowable Uniform Floor and Roof Load Tables," page 41.

# Allowable Uniform Roof Loads (PLF) – 115% (Snow)

(Can be applied to the beam in addition to its own weight.)

## 2.0E GP Lam® LVL

Span	Condition	Three 1 3/4" GP Lam LVL								Four 1 3/4" GP Lam LVL								
		9 1/4"	9 1/2"	11 1/4"	11 1/2"	14"	16"	18"	24"	9 1/4"	9 1/2"	11 1/4"	11 1/2"	14"	16"	18"	24"	
6'	Live Load L/240																	
	Total Load	3549	3670	4573	4729	4726	4723	4720	4712	4731	4894	6097	6305	6301	6298	6294	6283	
	End / Int. Bearing	3.6 / 9.0	3.7 / 9.3	4.6 / 11.6	4.8 / 12.0	4.8 / 12.0	4.8 / 12.0	4.8 / 12.0	4.8 / 12.0	3.6 / 9.0	3.7 / 9.3	4.6 / 11.6	4.8 / 12.0	4.8 / 12.0	4.8 / 12.0	4.8 / 12.0	4.8 / 12.0	
8'	Live Load L/240																	
	Total Load	2496	2576	3161	3380	3540	3537	3534	3525	3328	3435	4214	4506	4719	4716	4712	4701	
	End / Int. Bearing	3.4 / 8.5	3.5 / 8.7	4.3 / 10.7	4.6 / 11.5	4.8 / 12.0	4.8 / 12.0	4.8 / 12.0	4.8 / 12.0	3.4 / 8.5	3.5 / 8.7	4.3 / 10.7	4.6 / 11.5	4.8 / 12.0	4.8 / 12.0	4.8 / 12.0	4.8 / 12.0	
10'	Live Load L/240																	
	Total Load	1410	1521	2413	2573	2828	2825	2822	2813	1880	2028	2495	2495	2901	3770	3766	3763	3751
	End / Int. Bearing	2.9 / 7.2	3.0 / 7.6	4.1 / 10.2	4.4 / 10.9	4.8 / 12.0	4.8 / 12.0	4.8 / 12.0	4.8 / 12.0	2.9 / 7.2	3.0 / 7.6	4.1 / 10.2	4.4 / 10.9	4.8 / 12.0	4.8 / 12.0	4.8 / 12.0	4.8 / 12.0	4.8 / 12.0
11'	Live Load L/240																	
	Total Load	1075	1160	1871	2176	2176	2176	2176	2176	1434	1547	2495	2495	2901	3425	3421	3418	3406
	End / Int. Bearing	2.6 / 6.6	2.8 / 6.9	3.8 / 9.5	4.2 / 10.5	4.8 / 12.0	4.8 / 12.0	4.8 / 12.0	4.8 / 12.0	2.6 / 6.6	2.8 / 6.9	3.8 / 9.5	4.2 / 10.5	4.8 / 12.0	4.8 / 12.0	4.8 / 12.0	4.8 / 12.0	4.8 / 12.0
12'	Live Load L/240																	
	Total Load	838	904	1465	1706	1890	2353	2350	2347	1117	1206	1953	2275	2521	3137	3134	3130	3119
	End / Int. Bearing	2.3 / 5.6	2.4 / 6.1	3.5 / 8.7	3.9 / 9.6	4.8 / 12.0	4.8 / 12.0	4.8 / 12.0	4.8 / 12.0	2.3 / 5.6	2.4 / 6.1	3.5 / 8.7	3.9 / 9.6	4.8 / 12.0	4.8 / 12.0	4.8 / 12.0	4.8 / 12.0	4.8 / 12.0
13'	Live Load L/240																	
	Total Load	665	718	1167	1361	2161	2161	2168	2165	886	957	1556	1815	2882	2890	2886	2875	2875
	End / Int. Bearing	1.9 / 4.9	2.1 / 5.2	3.2 / 8.0	3.6 / 8.9	4.8 / 12.0	4.8 / 12.0	4.8 / 12.0	4.8 / 12.0	1.9 / 4.9	2.1 / 5.2	3.2 / 8.0	3.6 / 8.9	4.8 / 12.0	4.8 / 12.0	4.8 / 12.0	4.8 / 12.0	4.8 / 12.0
14'	Live Load L/240																	
	Total Load	536	579	944	1102	1757	1757	2011	2008	715	772	1259	1469	2343	2682	2678	2667	2667
	End / Int. Bearing	1.7 / 4.2	1.8 / 4.6	3.0 / 7.4	3.3 / 8.3	4.5 / 11.3	4.8 / 12.0	4.8 / 12.0	4.8 / 12.0	1.7 / 4.2	1.8 / 4.6	3.0 / 7.4	3.3 / 8.3	4.5 / 11.3	4.8 / 12.0	4.8 / 12.0	4.8 / 12.0	4.8 / 12.0
15'	Live Load L/240																	
	Total Load	438	474	774	904	1446	1446	1876	1873	584	632	1032	1206	1929	2501	2497	2486	2486
	End / Int. Bearing	1.5 / 3.7	1.6 / 4.0	2.6 / 6.5	3.0 / 7.6	4.2 / 10.5	4.8 / 12.0	4.8 / 12.0	4.8 / 12.0	1.5 / 3.7	1.6 / 4.0	2.6 / 6.5	3.0 / 7.6	4.2 / 10.5	4.8 / 12.0	4.8 / 12.0	4.8 / 12.0	4.8 / 12.0
16'	Live Load L/240																	
	Total Load	363	392	642	751	1204	1444	1757	1754	484	523	856	1001	1606	2343	2339	2328	2328
	End / Int. Bearing	1.5 / 3.3	1.5 / 3.5	2.3 / 5.8	2.7 / 6.7	3.9 / 9.9	4.8 / 12.0	4.8 / 12.0	4.8 / 12.0	1.5 / 3.3	1.5 / 3.5	2.3 / 5.8	2.7 / 6.7	3.9 / 9.9	4.8 / 12.0	4.8 / 12.0	4.8 / 12.0	4.8 / 12.0
17'	Live Load L/240																	
	Total Load	304	328	538	630	1013	1481	1646	1649	405	438	718	840	1350	1975	2199	2188	2188
	End / Int. Bearing	1.5 / 3.0	1.5 / 3.0	2.1 / 5.1	2.4 / 6.0	3.7 / 9.3	4.8 / 12.0	4.8 / 12.0	4.8 / 12.0	1.5 / 3.0	1.5 / 3.1	2.1 / 5.1	2.4 / 6.0	3.7 / 9.3	4.8 / 12.0	4.8 / 12.0	4.8 / 12.0	4.8 / 12.0
18'	Live Load L/240																	
	Total Load	257	278	456	534	859	1259	1466	1548	342	370	608	711	1146	1679	2075	2064	2064
	End / Int. Bearing	1.5 / 3.0	1.5 / 3.0	1.8 / 4.6	2.2 / 5.4	3.5 / 8.7	4.5 / 11.3	4.8 / 12.0	4.8 / 12.0	1.5 / 3.0	1.5 / 3.0	1.8 / 4.6	2.2 / 5.4	3.5 / 8.7	4.5 / 11.3	4.8 / 12.0	4.8 / 12.0	4.8 / 12.0
19'	Live Load L/240																	
	Total Load	219	237	389	456	735	1080	1313	1473	292	316	519	608	980	1439	1964	1953	1953
	End / Int. Bearing	1.5 / 3.0	1.5 / 3.0	1.7 / 4.2	1.9 / 4.9	3.1 / 7.8	4.3 / 10.7	4.8 / 12.0	4.8 / 12.0	1.5 / 3.0	1.5 / 3.0	1.7 / 4.2	1.9 / 4.9	3.1 / 7.8	4.3 / 10.7	4.8 / 12.0	4.8 / 12.0	4.8 / 12.0
20'	Live Load L/240																	
	Total Load	188	203	335	392	634	932	1305	1390	251	271	446	523	845	1243	1740	1853	1853
	End / Int. Bearing	1.5 / 3.0	1.5 / 3.0	1.5 / 3.8	1.8 / 4.4	2.8 / 7.1	4.1 / 10.2	4.8 / 12.0	4.8 / 12.0	1.5 / 3.0	1.5 / 3.0	1.5 / 3.8	1.8 / 4.4	2.8 / 7.1	4.1 / 10.2	4.8 / 12.0	4.8 / 12.0	4.8 / 12.0
22'	Live Load L/240																	
	Total Load	142	153	253	297	480	708	994	1260	189	205	337	395	640	944	1325	1680	1680
	End / Int. Bearing	1.5 / 3.0	1.5 / 3.0	1.5 / 3.1	1.5 / 3.7	2.4 / 5.9	3.5 / 8.8	4.6 / 11.5	4.8 / 12.0	1.5 / 3.0	1.5 / 3.0	1.5 / 3.1	1.5 / 3.7	2.4 / 5.9	3.5 / 8.8	4.6 / 11.5	4.8 / 12.0	4.8 / 12.0
24'	Live Load L/240																	
	Total Load	109	118	196	230	372	550	774	1152	146	158	261	306	497	733	1032	1537	1537
	End / Int. Bearing	1.5 / 3.0	1.5 / 3.0	1.5 / 3.0	1.5 / 3.1	2.0 / 5.0	3.0 / 7.4	4.2 / 10.4	4.8 / 12.0	1.5 / 3.0	1.5 / 3.0	1.5 / 3.0	1.5 / 3.1	2.0 / 5.0	3.0 / 7.4	4.2 / 10.4	4.8 / 12.0	4.8 / 12.0
26'	Live Load L/240																	
	Total Load	86	93	154	181	294	436	614	1061	115	124	206	242	393	581	818	1415	1415
	End / Int. Bearing	1.5 / 3.0	1.5 / 3.0	1.5 / 3.0	1.5 / 3.0	1.7 / 4.3	2.5 / 6.4	3.6 / 9.0	4.8 / 12.0	1.5 / 3.0	1.5 / 3.0	1.5 / 3.0	1.5 / 3.0	1.7 / 4.3	2.5 / 6.4	3.6 / 9.0	4.8 / 12.0	4.8 / 12.0
28'	Live Load L/240																	
	Total Load	69	75	124	145	237	351	495	983	92	100	165	194	316	467	660	1311	1311
	End / Int. Bearing	1.5 / 3.0	1.5 / 3.0	1.5 / 3.0	1.5 / 3.0	1.5 / 3.7	2.2 / 5.5	3.1 / 7.8	4.8 / 12.0	1.5 / 3.0	1.5 / 3.0	1.5 / 3.0	1.5 / 3.0	1.5 / 3.7	2.2 / 5.5	3.1 / 7.8	4.8 / 12.0	4.8 / 12.0

### KEY TO TABLES

**Live Load L/240** = Maximum live load — limits deflection to L/240

**Total Load** = Maximum total load — limits deflection to L/180

**End/Int. Bearing** = Required minimum end bearing (inches) for simple or multiple span beams and minimum interior bearing (inches) for multiple span beams based on plate bearing stress of 565 psi.

See "Using Allowable Uniform Floor and Roof Load Tables," page 41.

# Allowable Uniform Roof Loads (PLF) – 125% (Non-Snow)

(Can be applied to the beam in addition to its own weight.)

## 2.0E GP Lam® LVL

Span	Condition	One 1 1/4" GP Lam LVL						Two 1 1/4" GP Lam LVL								
		7'"	9'"	9 1/2'"	11'"	11 1/2'"	14'"	7'"	9'"	9 1/2'"	11'"	11 1/2'"	14'"	16'"	18'"	24'"
6'	Live Load L/240															
	Total Load	954	1286	1330	1577	1576	1575	1909	2572	2660	3153	3153	3151	3149	3147	3141
	End / Int. Bearing	2.9 / 7.3	3.9 / 9.8	4.0 / 10.1	4.8 / 12.0	4.8 / 12.0	4.8 / 12.0	2.9 / 7.3	3.9 / 9.8	4.0 / 10.1	4.8 / 12.0	4.8 / 12.0	4.8 / 12.0	4.8 / 12.0	4.8 / 12.0	4.8 / 12.0
8'	Live Load L/240	444	877					887	1754							
	Total Load	588	905	934	1146	1181	1180	1176	1809	1867	2291	2362	2360	2358	2356	2350
	End / Int. Bearing	2.4 / 6.0	3.7 / 9.2	3.8 / 9.5	4.7 / 11.6	4.8 / 12.0	4.8 / 12.0	2.4 / 6.0	3.7 / 9.2	3.8 / 9.5	4.7 / 11.6	4.8 / 12.0	4.8 / 12.0	4.8 / 12.0	4.8 / 12.0	4.8 / 12.0
10'	Live Load L/240	234	470	507	813			468	940	1014	1626					
	Total Load	308	616	648	875	933	943	617	1233	1297	1750	1865	1885	1883	1881	1876
	End / Int. Bearing	1.6 / 3.9	3.1 / 7.8	3.3 / 8.3	4.5 / 11.1	4.7 / 11.9	4.8 / 12.0	1.6 / 3.9	3.1 / 7.8	3.3 / 8.3	4.5 / 11.1	4.7 / 11.9	4.8 / 12.0	4.8 / 12.0	4.8 / 12.0	4.8 / 12.0
11'	Live Load L/240	177	358	387	624	725		355	717	773	1248	1451				
	Total Load	233	473	511	737	817	856	466	947	1022	1474	1634	1713	1711	1709	1703
	End / Int. Bearing	1.5 / 3.3	2.7 / 6.6	2.9 / 7.2	4.1 / 10.3	4.6 / 11.4	4.8 / 12.0	1.5 / 3.3	2.7 / 6.6	2.9 / 7.2	4.1 / 10.3	4.6 / 11.4	4.8 / 12.0	4.8 / 12.0	4.8 / 12.0	4.8 / 12.0
12'	Live Load L/240	137	279	301	488	569		275	558	603	977	1137				
	Total Load	180	368	397	619	685	784	360	736	795	1237	1371	1569	1567	1565	1559
	End / Int. Bearing	1.5 / 3.0	2.3 / 5.6	2.4 / 6.1	3.8 / 9.5	4.2 / 10.5	4.8 / 12.0	1.5 / 3.0	2.3 / 5.6	2.4 / 6.1	3.8 / 9.5	4.2 / 10.5	4.8 / 12.0	4.8 / 12.0	4.8 / 12.0	4.8 / 12.0
13'	Live Load L/240	109	221	239	389	454	720	218	443	479	778	907	1441			
	Total Load	142	291	315	513	583	724	283	582	629	1027	1166	1447	1445	1443	1438
	End / Int. Bearing	1.5 / 3.0	1.9 / 4.9	2.1 / 5.2	3.4 / 8.5	3.9 / 9.7	4.8 / 12.0	1.5 / 3.0	1.9 / 4.9	2.1 / 5.2	3.4 / 8.5	3.9 / 9.7	4.8 / 12.0	4.8 / 12.0	4.8 / 12.0	4.8 / 12.0
14'	Live Load L/240	87	179	193	315	367	586	175	357	386	629	735	1171			
	Total Load	113	234	253	414	484	671	226	468	506	828	968	1343	1341	1339	1333
	End / Int. Bearing	1.5 / 3.0	1.7 / 4.2	1.8 / 4.6	3.0 / 7.4	3.5 / 8.7	4.8 / 12.0	1.5 / 3.0	1.7 / 4.2	1.8 / 4.6	3.0 / 7.4	3.5 / 8.7	4.8 / 12.0	4.8 / 12.0	4.8 / 12.0	4.8 / 12.0
15'	Live Load L/240	71	146	158	258	301	482	143	292	316	516	603	964			
	Total Load	92	190	206	339	396	597	184	381	412	677	793	1194	1250	1249	1243
	End / Int. Bearing	1.5 / 3.0	1.5 / 3.7	1.6 / 4.0	2.6 / 6.5	3.0 / 7.6	4.6 / 11.4	1.5 / 3.0	1.5 / 3.7	1.6 / 4.0	2.6 / 6.5	3.0 / 7.6	4.6 / 11.4	4.8 / 12.0	4.8 / 12.0	4.8 / 12.0
16'	Live Load L/240	59	121	131	214	250	401	118	242	262	428	501	803			
	Total Load	75	157	170	280	328	524	150	314	340	560	656	1048	1171	1169	1164
	End / Int. Bearing	1.5 / 3.0	1.5 / 3.3	1.5 / 3.5	2.3 / 5.8	2.7 / 6.7	4.3 / 10.7	1.5 / 3.0	1.5 / 3.3	1.5 / 3.5	2.3 / 5.8	2.7 / 6.7	4.3 / 10.7	4.8 / 12.0	4.8 / 12.0	4.8 / 12.0
17'	Live Load L/240	49	101	109	179	210	338	98	202	219	359	420	675	987		
	Total Load	62	130	141	234	274	443	124	261	283	468	549	887	1102	1100	1094
	End / Int. Bearing	1.5 / 3.0	1.5 / 3.0	1.5 / 3.1	2.1 / 5.1	2.4 / 6.0	3.9 / 9.7	1.5 / 3.0	1.5 / 3.0	1.5 / 3.1	2.1 / 5.1	2.4 / 6.0	3.9 / 9.7	4.8 / 12.0	4.8 / 12.0	4.8 / 12.0
18'	Live Load L/240	41	85	92	152	178	286	83	171	185	304	356	573	840		
	Total Load	52	109	119	197	232	375	104	219	238	394	463	751	1040	1038	1032
	End / Int. Bearing	1.5 / 3.0	1.5 / 3.0	1.5 / 3.0	1.8 / 4.6	2.2 / 5.4	3.5 / 8.7	1.5 / 3.0	1.5 / 3.0	1.5 / 3.0	1.8 / 4.6	2.2 / 5.4	3.5 / 8.7	4.8 / 12.0	4.8 / 12.0	4.8 / 12.0
19'	Live Load L/240		73	79	129	152	245	71	146	158	259	304	490	720		
	Total Load		93	100	168	197	320	87	186	201	335	394	640	944	982	976
	End / Int. Bearing		1.5 / 3.0	1.5 / 3.0	1.7 / 4.2	1.9 / 4.9	3.1 / 7.8	1.5 / 3.0	1.5 / 3.0	1.5 / 3.0	1.7 / 4.2	1.9 / 4.9	3.1 / 7.8	4.6 / 11.5	4.8 / 12.0	4.8 / 12.0
20'	Live Load L/240		62	67	111	131	211	61	125	135	223	262	423	621	870	
	Total Load		79	86	143	169	275	74	158	172	287	337	550	813	932	926
	End / Int. Bearing		1.5 / 3.0	1.5 / 3.0	1.5 / 3.8	1.8 / 4.4	2.8 / 7.1	1.5 / 3.0	1.5 / 3.0	1.5 / 3.0	1.5 / 3.8	1.8 / 4.4	2.8 / 7.1	4.2 / 10.5	4.8 / 12.0	4.8 / 12.0
22'	Live Load L/240		47	51	84	99	160	45	94	102	168	198	320	472	663	
	Total Load		58	63	107	126	207	54	117	127	214	252	414	614	846	840
	End / Int. Bearing		1.5 / 3.0	1.5 / 3.0	1.5 / 3.1	1.5 / 3.7	2.4 / 5.9	1.5 / 3.0	1.5 / 3.0	1.5 / 3.0	1.5 / 3.1	1.5 / 3.7	2.4 / 5.9	3.5 / 8.8	4.8 / 12.0	4.8 / 12.0
24'	Live Load L/240			39	65	76	124		73	79	130	153	248	367	516	
	Total Load			48	81	96	159		88	96	163	193	318	474	671	768
	End / Int. Bearing			1.5 / 3.0	1.5 / 3.0	1.5 / 3.1	2.0 / 5.0		1.5 / 3.0	1.5 / 3.0	1.5 / 3.0	1.5 / 3.1	2.0 / 5.0	3.0 / 7.4	4.2 / 10.4	4.8 / 12.0
26'	Live Load L/240			51	60	98			57	62	103	121	196	290	409	
	Total Load			63	75	124			68	74	126	150	248	372	529	707
	End / Int. Bearing			1.5 / 3.0	1.5 / 3.0	1.7 / 4.3			1.5 / 3.0	1.5 / 3.0	1.5 / 3.0	1.5 / 3.0	1.7 / 4.3	2.5 / 6.4	3.6 / 9.0	4.8 / 12.0
28'	Live Load L/240				41	48	79		46	50	82	97	158	234	330	
	Total Load				49	59	98		52	57	99	118	197	296	423	655
	End / Int. Bearing				1.5 / 3.0	1.5 / 3.0	1.5 / 3.7		1.5 / 3.0	1.5 / 3.0	1.5 / 3.0	1.5 / 3.0	1.5 / 3.7	2.2 / 5.5	3.1 / 7.8	4.8 / 12.0

### KEY TO TABLES

**Live Load L/240** = Maximum live load — limits deflection to L/240

**Total Load** = Maximum total load — limits deflection to L/180

**End / Int. Bearing** = Required minimum end bearing (inches) for simple or multiple span beams and minimum interior bearing (inches) for multiple span beams based on plate bearing stress of 565 psi.

See "Using Allowable Uniform Floor and Roof Load Tables," page 41.

## Allowable Uniform Roof Loads (PLF) – 125% (Non-Snow)

(Can be applied to the beam in addition to its own weight.)

### 2.0E GP Lam® LVL

Span	Condition	Three 1 1/4" GP Lam LVL								Four 1 3/4" GP Lam LVL							
		9 1/4"	9 1/2"	11 1/4"	11 1/2"	14"	16"	18"	24"	9 1/4"	9 1/2"	11 1/4"	11 1/2"	14"	16"	18"	24"
6'	Live Load L/240																
	Total Load	3858	3991	4730	4729	4726	4723	4720	4712	5144	5321	6307	6305	6301	6298	6294	6283
	End / Int. Bearing	3.9 / 9.8	4.0 / 10.1	4.8 / 12.0	4.8 / 12.0	4.8 / 12.0	4.8 / 12.0	4.8 / 12.0	4.8 / 12.0	3.9 / 9.8	4.0 / 10.1	4.8 / 12.0	4.8 / 12.0	4.8 / 12.0	4.8 / 12.0	4.8 / 12.0	4.8 / 12.0
8'	Live Load L/240	2631								3507							
	Total Load	2714	2801	3437	3543	3540	3537	3534	3525	3619	3735	4583	4723	4719	4716	4712	4701
	End / Int. Bearing	3.7 / 9.2	3.8 / 9.5	4.7 / 11.6	4.8 / 12.0	4.8 / 12.0	4.8 / 12.0	4.8 / 12.0	4.8 / 12.0	3.7 / 9.2	3.8 / 9.5	4.7 / 11.6	4.8 / 12.0	4.8 / 12.0	4.8 / 12.0	4.8 / 12.0	4.8 / 12.0
10'	Live Load L/240	1410	1521	2439						1880	2028	3252					
	Total Load	1849	1945	2624	2798	2828	2825	2822	2813	2466	2593	3499	3730	3770	3766	3763	3751
	End / Int. Bearing	3.1 / 7.8	3.3 / 8.3	4.5 / 11.1	4.7 / 11.9	4.8 / 12.0	4.8 / 12.0	4.8 / 12.0	4.8 / 12.0	3.1 / 7.8	3.3 / 8.3	4.5 / 11.1	4.7 / 11.9	4.8 / 12.0	4.8 / 12.0	4.8 / 12.0	4.8 / 12.0
11'	Live Load L/240	1075	1160	1871						1434	1547	2495					
	Total Load	1420	1533	2212	2450	2569	2566	2563	2555	1894	2045	2949	3267	3425	3421	3418	3406
	End / Int. Bearing	2.7 / 6.6	2.9 / 7.2	4.1 / 10.3	4.6 / 11.4	4.8 / 12.0	4.8 / 12.0	4.8 / 12.0	4.8 / 12.0	2.7 / 6.6	2.9 / 7.2	4.1 / 10.3	4.6 / 11.4	4.8 / 12.0	4.8 / 12.0	4.8 / 12.0	4.8 / 12.0
12'	Live Load L/240	838	904	1465	1706					1117	1206	1953	2275				
	Total Load	1104	1192	1856	2056	2353	2350	2347	2339	1471	1590	2475	2742	3137	3134	3130	3119
	End / Int. Bearing	2.3 / 5.6	2.4 / 6.1	3.8 / 9.5	4.2 / 10.5	4.8 / 12.0	4.8 / 12.0	4.8 / 12.0	4.8 / 12.0	2.3 / 5.6	2.4 / 6.1	3.8 / 9.5	4.2 / 10.5	4.8 / 12.0	4.8 / 12.0	4.8 / 12.0	4.8 / 12.0
13'	Live Load L/240	665	718	1167	1361	2161				886	957	1556	1815	2882			
	Total Load	873	944	1540	1750	2171	2168	2165	2156	1164	1258	2053	2333	2894	2890	2886	2875
	End / Int. Bearing	1.9 / 4.9	2.1 / 5.2	3.4 / 8.5	3.9 / 9.7	4.8 / 12.0	4.8 / 12.0	4.8 / 12.0	4.8 / 12.0	1.9 / 4.9	2.1 / 5.2	3.4 / 8.5	3.9 / 9.7	4.8 / 12.0	4.8 / 12.0	4.8 / 12.0	4.8 / 12.0
14'	Live Load L/240	536	579	944	1102	1757				715	772	1259	1469	2343			
	Total Load	701	759	1243	1453	2014	2011	2008	2000	935	1012	1657	1937	2685	2682	2678	2667
	End / Int. Bearing	1.7 / 4.2	1.8 / 4.6	3.0 / 7.4	3.5 / 8.7	4.8 / 12.0	4.8 / 12.0	4.8 / 12.0	4.8 / 12.0	1.7 / 4.2	1.8 / 4.6	3.0 / 7.4	3.5 / 8.7	4.8 / 12.0	4.8 / 12.0	4.8 / 12.0	4.8 / 12.0
15'	Live Load L/240	438	474	774	904	1446				584	632	1032	1206	1929			
	Total Load	571	618	1016	1189	1791	1876	1873	1864	761	824	1354	1585	2388	2501	2497	2486
	End / Int. Bearing	1.5 / 3.7	1.6 / 4.0	2.6 / 6.5	3.0 / 7.6	4.6 / 11.4	4.8 / 12.0	4.8 / 12.0	4.8 / 12.0	1.5 / 3.7	1.6 / 4.0	2.6 / 6.5	3.0 / 7.6	4.6 / 11.4	4.8 / 12.0	4.8 / 12.0	4.8 / 12.0
16'	Live Load L/240	363	392	642	751	1204				484	523	856	1001	1606			
	Total Load	471	510	840	984	1572	1757	1754	1746	627	679	1120	1312	2095	2343	2339	2328
	End / Int. Bearing	1.5 / 3.3	1.5 / 3.5	2.3 / 5.8	2.7 / 6.7	4.3 / 10.7	4.8 / 12.0	4.8 / 12.0	4.8 / 12.0	1.5 / 3.3	1.5 / 3.5	2.3 / 5.8	2.7 / 6.7	4.3 / 10.7	4.8 / 12.0	4.8 / 12.0	4.8 / 12.0
17'	Live Load L/240	304	328	538	630	1013	1481			405	438	718	840	1350	1975		
	Total Load	392	424	702	823	1330	1652	1649	1641	522	566	936	1097	1774	2203	2199	2188
	End / Int. Bearing	1.5 / 3.0	1.5 / 3.1	2.1 / 5.1	2.4 / 6.0	3.9 / 9.7	4.8 / 12.0	4.8 / 12.0	4.8 / 12.0	1.5 / 3.0	1.5 / 3.1	2.1 / 5.1	2.4 / 6.0	3.9 / 9.7	4.8 / 12.0	4.8 / 12.0	4.8 / 12.0
18'	Live Load L/240	257	278	456	534	859	1259			342	370	608	711	1146	1679		
	Total Load	329	357	592	695	1126	1559	1556	1548	439	476	789	926	1501	2079	2075	2064
	End / Int. Bearing	1.5 / 3.0	1.5 / 3.0	1.8 / 4.6	2.2 / 5.4	3.5 / 8.7	4.8 / 12.0	4.8 / 12.0	4.8 / 12.0	1.5 / 3.0	1.5 / 3.0	1.8 / 4.6	2.2 / 5.4	3.5 / 8.7	4.8 / 12.0	4.8 / 12.0	4.8 / 12.0
19'	Live Load L/240	219	237	389	456	735	1080			292	316	519	608	980	1439		
	Total Load	279	302	503	591	961	1417	1473	1465	372	403	670	788	1281	1889	1964	1953
	End / Int. Bearing	1.5 / 3.0	1.5 / 3.0	1.7 / 4.2	1.9 / 4.9	3.1 / 7.8	4.6 / 11.5	4.8 / 12.0	4.8 / 12.0	1.5 / 3.0	1.5 / 3.0	1.7 / 4.2	1.9 / 4.9	3.1 / 7.8	4.6 / 11.5	4.8 / 12.0	4.8 / 12.0
20'	Live Load L/240	188	203	335	392	634	932	1305		251	271	446	523	845	1243	1740	
	Total Load	238	258	430	506	825	1220	1398	1390	317	344	574	675	1100	1626	1864	1853
	End / Int. Bearing	1.5 / 3.0	1.5 / 3.0	1.5 / 3.8	1.8 / 4.4	2.8 / 7.1	4.2 / 10.5	4.8 / 12.0	4.8 / 12.0	1.5 / 3.0	1.5 / 3.0	1.5 / 3.8	1.8 / 4.4	2.8 / 7.1	4.2 / 10.5	4.8 / 12.0	4.8 / 12.0
22'	Live Load L/240	142	153	253	297	480	708	994		189	205	337	395	640	944	1325	
	Total Load	176	191	321	379	621	921	1269	1260	235	255	428	505	827	1228	1692	1680
	End / Int. Bearing	1.5 / 3.0	1.5 / 3.0	1.5 / 3.1	1.5 / 3.7	2.4 / 5.9	3.5 / 8.8	4.8 / 12.0	4.8 / 12.0	1.5 / 3.0	1.5 / 3.0	1.5 / 3.1	1.5 / 3.7	2.4 / 5.9	3.5 / 8.8	4.8 / 12.0	4.8 / 12.0
24'	Live Load L/240	109	118	196	230	372	550	774		146	158	261	306	497	733	1032	
	Total Load	133	145	245	289	477	711	1006	1152	177	193	327	386	636	948	1342	1537
	End / Int. Bearing	1.5 / 3.0	1.5 / 3.0	1.5 / 3.0	1.5 / 3.1	2.0 / 5.0	3.0 / 7.4	4.2 / 10.4	4.8 / 12.0	1.5 / 3.0	1.5 / 3.0	1.5 / 3.0	1.5 / 3.1	2.0 / 5.0	3.0 / 7.4	4.2 / 10.4	4.8 / 12.0
26'	Live Load L/240	86	93	154	181	294	436	614		115	124	206	242	393	581	818	
	Total Load	102	111	190	225	373	558	793	1061	136	148	253	300	497	744	1057	1415
	End / Int. Bearing	1.5 / 3.0	1.5 / 3.0	1.5 / 3.0	1.5 / 3.0	1.7 / 4.3	2.5 / 6.4	3.6 / 9.0	4.8 / 12.0	1.5 / 3.0	1.5 / 3.0	1.5 / 3.0	1.5 / 3.0	1.7 / 4.3	2.5 / 6.4	3.6 / 9.0	4.8 / 12.0
28'	Live Load L/240	69	75	124	145	237	351	495		92	100	165	194	316	467	660	
	Total Load	79	86	149	177	296	445	634	983	105	115	199	236	394	593	845	1311
	End / Int. Bearing	1.5 / 3.0	1.5 / 3.0	1.5 / 3.0	1.5 / 3.0	1.5 / 3.7	2.2 / 5.5	3.1 / 7.8	4.8 / 12.0	1.5 / 3.0	1.5 / 3.0	1.5 / 3.0	1.5 / 3.0	1.5 / 3.7	2.2 / 5.5	3.1 / 7.8	4.8 / 12.0

#### KEY TO TABLES

**Live Load L/240** = Maximum live load — limits deflection to L/240

**Total Load** = Maximum total load — limits deflection to L/180

**End/Int. Bearing** = Required minimum end bearing (inches) for simple or multiple span beams and minimum interior bearing (inches) for multiple span beams based on plate bearing stress of 565 psi.

See "Using Allowable Uniform Floor and Roof Load Tables," page 41.



# Allowable Uniform Floor Loads (PLF) – 100%

(Can be applied to the beam in addition to its own weight.)

## 1.5E GP Lam® LVL

Span	Condition	One 1 3/4" GP Lam LVL						Two 1 3/4" GP Lam LVL								
		7 1/4"	9 1/4"	9 1/2"	11 1/4"	11 1/2"	14"	4 1/2"	5 1/2"	7 1/4"	9 1/4"	9 1/2"	11 1/4"	11 1/2"	14"	16"
6'	Live Load L/360	495	947	1015				279	458	989	1895	2030				
	Total Load	687	1028	1063	1325	1425	1576	415	682	1374	2056	2127	2650	2850	3151	3150
	End / Int. Bearing	2.1 / 5.2	3.1 / 7.8	3.2 / 8.1	4.0 / 10.1	4.3 / 10.8	4.8 / 12.0	1.5 / 3.0	1.5 / 3.0	2.1 / 5.2	3.1 / 7.8	3.2 / 8.1	4.0 / 10.1	4.3 / 10.8	4.8 / 12.0	4.8 / 12.0
8'	Live Load L/360	222	438	472	744	858		121	200	444	877	943	1488	1716		
	Total Load	329	605	635	869	960	1180	177	296	659	1209	1270	1737	1920	2360	2359
	End / Int. Bearing	1.5 / 3.4	2.5 / 6.2	2.6 / 6.5	3.5 / 8.8	3.9 / 9.8	4.8 / 12.0	1.5 / 3.0	1.5 / 3.0	1.5 / 3.4	2.5 / 6.2	2.6 / 6.5	3.5 / 8.8	3.9 / 9.8	4.8 / 12.0	4.8 / 12.0
10'	Live Load L/360	117	235	253	407	472	735	62	104	234	470	507	813	943	1471	
	Total Load	172	348	376	554	613	831	90	152	344	697	752	1108	1225	1662	1884
	End / Int. Bearing	1.5 / 3.0	1.8 / 4.5	1.9 / 4.8	2.8 / 7.1	3.1 / 7.8	4.2 / 10.6	1.5 / 3.0	1.5 / 3.0	1.5 / 3.0	1.8 / 4.5	1.9 / 4.8	2.8 / 7.1	3.1 / 7.8	4.2 / 10.6	4.8 / 12.0
11'	Live Load L/360	88	179	193	312	363	570	47	79	177	358	387	624	725	1139	1627
	Total Load	130	265	286	457	505	686	66	113	260	529	572	914	1011	1372	1711
	End / Int. Bearing	1.5 / 3.0	1.5 / 3.7	1.6 / 4.0	2.6 / 6.4	2.8 / 7.1	3.8 / 9.6	1.5 / 3.0	1.5 / 3.0	1.5 / 3.0	1.5 / 3.7	1.6 / 4.0	2.6 / 6.4	2.8 / 7.1	3.8 / 9.6	4.8 / 12.0
12'	Live Load L/360	68	139	150	244	284	449		61	137	279	301	488	569	899	1291
	Total Load	100	205	222	361	421	575		86	200	410	444	722	842	1150	1474
	End / Int. Bearing	1.5 / 3.0	1.5 / 3.2	1.5 / 3.4	2.2 / 5.6	2.6 / 6.5	3.5 / 8.8		1.5 / 3.0	1.5 / 3.0	1.5 / 3.2	1.5 / 3.4	2.2 / 5.6	2.6 / 6.5	3.5 / 8.8	4.5 / 11.3
13'	Live Load L/360	54	110	119	194	227	360		48	108	221	239	389	454	720	1040
	Total Load	78	162	175	287	335	489		67	157	324	350	573	670	978	1254
	End / Int. Bearing	1.5 / 3.0	1.5 / 3.0	1.5 / 3.0	1.9 / 4.8	2.2 / 5.6	3.3 / 8.1		1.5 / 3.0	1.5 / 3.0	1.5 / 3.0	1.5 / 3.0	1.9 / 4.8	2.2 / 5.6	3.3 / 8.1	4.2 / 10.4
14'	Live Load L/360	43	89	96	157	183	293		87	178	193	315	367	586	849	
	Total Load	62	130	140	231	270	421		125	260	281	462	540	842	1079	
	End / Int. Bearing	1.5 / 3.0	1.5 / 3.0	1.5 / 3.0	1.7 / 4.2	2.0 / 4.9	3.0 / 7.6		1.5 / 3.0	1.5 / 3.0	1.5 / 3.0	1.7 / 4.2	2.0 / 4.9	3.0 / 7.6	3.9 / 9.7	
15'	Live Load L/360		73	79	129	150	241		71	146	158	258	301	482	701	
	Total Load		105	114	188	221	355		100	211	228	377	441	711	938	
	End / Int. Bearing		1.5 / 3.0	1.5 / 3.0	1.5 / 3.7	1.7 / 4.3	2.7 / 6.9		1.5 / 3.0	1.5 / 3.0	1.5 / 3.0	1.5 / 3.7	1.7 / 4.3	2.7 / 6.9	3.6 / 9.0	
16'	Live Load L/360		60	65	107	125	200		59	121	130	214	250	401	586	
	Total Load		86	93	155	182	295		82	173	187	311	365	590	823	
	End / Int. Bearing		1.5 / 3.0	1.5 / 3.0	1.5 / 3.2	1.5 / 3.8	2.4 / 6.1		1.5 / 3.0	1.5 / 3.0	1.5 / 3.0	1.5 / 3.2	1.5 / 3.8	2.4 / 6.1	3.4 / 8.5	
17'	Live Load L/360		50	54	89	105	169		49	101	109	179	210	338	494	
	Total Load		71	77	129	152	247		67	143	155	259	304	494	726	
	End / Int. Bearing		1.5 / 3.0	1.5 / 3.0	1.5 / 3.0	1.5 / 3.4	2.2 / 5.4		1.5 / 3.0	1.5 / 3.0	1.5 / 3.0	1.5 / 3.0	1.5 / 3.4	2.2 / 5.4	3.2 / 8.0	
18'	Live Load L/360		42	46	76	89	143		41	85	92	152	178	286	420	
	Total Load		60	65	109	128	208		56	120	130	218	256	417	615	
	End / Int. Bearing		1.5 / 3.0	1.5 / 3.0	1.5 / 3.0	1.5 / 3.0	2.0 / 4.9		1.5 / 3.0	1.5 / 3.0	1.5 / 3.0	1.5 / 3.0	1.5 / 3.0	2.0 / 4.9	2.9 / 7.2	
19'	Live Load L/360				64	76	122				73	79	129	152	245	360
	Total Load				92	108	177				101	110	184	217	355	525
	End / Int. Bearing				1.5 / 3.0	1.5 / 3.0	1.8 / 4.4				1.5 / 3.0	1.5 / 3.0	1.5 / 3.0	1.5 / 3.0	1.8 / 4.4	2.6 / 6.5
20'	Live Load L/360				55	65	105				62	67	111	130	211	311
	Total Load				78	92	152				85	93	157	185	304	452
	End / Int. Bearing				1.5 / 3.0	1.5 / 3.0	1.6 / 4.0				1.5 / 3.0	1.5 / 3.0	1.5 / 3.0	1.5 / 3.0	1.6 / 4.0	2.4 / 5.9
22'	Live Load L/360				42	49	80				47	51	84	98	160	236
	Total Load				58	68	114				62	68	116	137	228	340
	End / Int. Bearing				1.5 / 3.0	1.5 / 3.0	1.5 / 3.3				1.5 / 3.0	1.5 / 3.0	1.5 / 3.0	1.5 / 3.0	1.5 / 3.3	2.0 / 4.9
24'	Live Load L/360						62						65	76	124	183
	Total Load						86						87	104	173	261
	End / Int. Bearing						1.5 / 3.0						1.5 / 3.0	1.5 / 3.0	1.5 / 3.0	1.7 / 4.2
26'	Live Load L/360						49						51	60	98	145
	Total Load						67						67	80	134	203
	End / Int. Bearing						1.5 / 3.0						1.5 / 3.0	1.5 / 3.0	1.5 / 3.0	1.5 / 3.6
28'	Live Load L/360												41	48	79	117
	Total Load												51	62	106	161
	End / Int. Bearing												1.5 / 3.0	1.5 / 3.0	1.5 / 3.0	1.5 / 3.1

### KEY TO TABLES

**Live Load L/360** = Maximum live load — limits deflection to L/360

**Total Load** = Maximum total load — limits deflection to L/240

**End / Int. Bearing** = Required minimum end bearing (inches) for simple or multiple span beams and minimum interior bearing (inches) for multiple span beams based on plate bearing stress of 565 psi.

See "Using Allowable Uniform Floor and Roof Load Tables," page 41.

# Allowable Uniform Roof Loads (PLF) – 115% (Snow)

(Can be applied to the beam in addition to its own weight.)

## 1.5E GP Lam® LVL

Span	Condition	One 1½" GP Lam LVL						Two 1½" GP Lam LVL								
		7¼"	9¼"	9½"	11¼"	11½"	14"	4¼"	5½"	7¼"	9¼"	9½"	11¼"	11½"	14"	16"
6'	Live Load L/240	742						419	687	1484						
	Total Load	791	1183	1224	1524	1577	1576	554	911	1581	2366	2447	3049	3153	3151	3150
	End / Int. Bearing	2.4 / 6.0	3.6 / 9.0	3.7 / 9.3	4.6 / 11.6	4.8 / 12.0	4.8 / 12.0	1.5 / 3.0	1.5 / 3.5	2.4 / 6.0	3.6 / 9.0	3.7 / 9.3	4.6 / 11.6	4.8 / 12.0	4.8 / 12.0	4.8 / 12.0
8'	Live Load L/240	333	658	708				181	301	665	1315	1415				
	Total Load	440	696	731	1000	1105	1180	238	396	881	1392	1462	2000	2210	2360	2359
	End / Int. Bearing	1.8 / 4.5	2.8 / 7.1	3.0 / 7.4	4.1 / 10.2	4.5 / 11.2	4.8 / 12.0	1.5 / 3.0	1.5 / 3.0	1.8 / 4.5	2.8 / 7.1	3.0 / 7.4	4.1 / 10.2	4.5 / 11.2	4.8 / 12.0	4.8 / 12.0
10'	Live Load L/240	175	353	380	610			94	157	351	705	760	1220			
	Total Load	231	444	466	638	705	943	121	204	461	888	933	1276	1411	1886	1884
	End / Int. Bearing	1.5 / 3.0	2.3 / 5.7	2.4 / 6.0	3.3 / 8.1	3.6 / 9.0	4.8 / 12.0	1.5 / 3.0	1.5 / 3.0	1.5 / 3.0	2.3 / 5.7	2.4 / 6.0	3.3 / 8.1	3.6 / 9.0	4.8 / 12.0	4.8 / 12.0
11'	Live Load L/240	133	269	290	468	544		71	118	266	538	580	936	1088		
	Total Load	174	354	382	526	582	790	90	153	348	708	765	1053	1164	1579	1711
	End / Int. Bearing	1.5 / 3.0	2.0 / 5.0	2.2 / 5.4	3.0 / 7.4	3.3 / 8.2	4.4 / 11.1	1.5 / 3.0	1.5 / 3.0	1.5 / 3.0	2.0 / 5.0	2.2 / 5.4	3.0 / 7.4	3.3 / 8.2	4.4 / 11.1	4.8 / 12.0
12'	Live Load L/240	103	209	226	366	427		54	91	206	419	452	732	853		
	Total Load	134	275	297	442	488	662	69	117	269	550	594	883	976	1325	1568
	End / Int. Bearing	1.5 / 3.0	1.7 / 4.2	1.8 / 4.6	2.7 / 6.8	3.0 / 7.5	4.1 / 10.1	1.5 / 3.0	1.5 / 3.0	1.5 / 3.0	1.7 / 4.2	1.8 / 4.6	2.7 / 6.8	3.0 / 7.5	4.1 / 10.1	4.8 / 12.0
13'	Live Load L/240	81	166	179	292	340	540	43	72	163	332	359	583	680	1081	
	Total Load	105	217	235	375	415	564	53	91	211	435	470	751	830	1127	1444
	End / Int. Bearing	1.5 / 3.0	1.5 / 3.6	1.6 / 3.9	2.5 / 6.3	2.8 / 6.9	3.7 / 9.4	1.5 / 3.0	1.5 / 3.0	1.5 / 3.0	1.5 / 3.6	1.6 / 3.9	2.5 / 6.3	2.8 / 6.9	3.7 / 9.4	4.8 / 12.0
14'	Live Load L/240	65	134	145	236	276	439		58	131	268	290	472	551	879	
	Total Load	84	174	189	310	357	485		72	168	349	378	619	714	970	1243
	End / Int. Bearing	1.5 / 3.0	1.5 / 3.2	1.5 / 3.4	2.2 / 5.6	2.6 / 6.4	3.5 / 8.7		1.5 / 3.0	1.5 / 3.0	1.5 / 3.2	1.5 / 3.4	2.2 / 5.6	2.6 / 6.4	3.5 / 8.7	4.5 / 11.1
15'	Live Load L/240	53	109	118	193	226	362		47	107	219	237	387	452	723	1052
	Total Load	68	142	154	253	296	422		58	136	284	307	506	592	843	1081
	End / Int. Bearing	1.5 / 3.0	1.5 / 3.0	1.5 / 3.0	2.0 / 4.9	2.3 / 5.7	3.2 / 8.1		1.5 / 3.0	1.5 / 3.0	1.5 / 3.0	1.5 / 3.0	2.0 / 4.9	2.3 / 5.7	3.2 / 8.1	4.2 / 10.4
16'	Live Load L/240	44	90	98	160	188	301		39	88	181	196	321	375	602	879
	Total Load	55	117	126	209	245	370		47	111	234	253	418	490	740	948
	End / Int. Bearing	1.5 / 3.0	1.5 / 3.0	1.5 / 3.0	1.7 / 4.3	2.0 / 5.1	3.0 / 7.6		1.5 / 3.0	1.5 / 3.0	1.5 / 3.0	1.5 / 3.0	1.7 / 4.3	2.0 / 5.1	3.0 / 7.6	3.9 / 9.7
17'	Live Load L/240	37	76	82	134	157	253			74	152	164	269	315	506	741
	Total Load	46	97	105	174	205	327			92	194	210	349	409	654	838
	End / Int. Bearing	1.5 / 3.0	1.5 / 3.0	1.5 / 3.0	1.5 / 3.9	1.8 / 4.5	2.9 / 7.2			1.5 / 3.0	1.5 / 3.0	1.5 / 3.0	1.5 / 3.9	1.8 / 4.5	2.9 / 7.2	3.7 / 9.2
18'	Live Load L/240		64	69	114	133	215			62	128	139	228	267	430	630
	Total Load		81	88	147	172	280			76	163	177	294	345	560	746
	End / Int. Bearing		1.5 / 3.0	1.5 / 3.0	1.5 / 3.5	1.6 / 4.0	2.6 / 6.5			1.5 / 3.0	1.5 / 3.0	1.5 / 3.0	1.5 / 3.5	1.6 / 4.0	2.6 / 6.5	3.5 / 8.7
19'	Live Load L/240		54	59	97	114	184			53	109	118	194	228	368	540
	Total Load		68	74	124	146	239			64	137	149	249	293	478	668
	End / Int. Bearing		1.5 / 3.0	1.5 / 3.0	1.5 / 3.1	1.5 / 3.6	2.4 / 5.9			1.5 / 3.0	1.5 / 3.0	1.5 / 3.0	1.5 / 3.1	1.5 / 3.6	2.4 / 5.9	3.3 / 8.2
20'	Live Load L/240		47	50	83	98	158			45	94	101	167	196	317	466
	Total Load		58	63	106	125	205			54	117	127	213	251	410	602
	End / Int. Bearing		1.5 / 3.0	1.5 / 3.0	1.5 / 3.0	1.5 / 3.3	2.1 / 5.3			1.5 / 3.0	1.5 / 3.0	1.5 / 3.0	1.5 / 3.0	1.5 / 3.3	2.1 / 5.3	3.1 / 7.8
22'	Live Load L/240			38	63	74	120				71	76	126	148	240	354
	Total Load			47	79	93	154				86	94	158	187	308	458
	End / Int. Bearing			1.5 / 3.0	1.5 / 3.0	1.5 / 3.0	1.8 / 4.5				1.5 / 3.0	1.5 / 3.0	1.5 / 3.0	1.5 / 3.0	1.8 / 4.5	2.6 / 6.6
24'	Live Load L/240			49	57	93					54	59	98	115	186	275
	Total Load			60	71	118					64	70	120	142	236	352
	End / Int. Bearing			1.5 / 3.0	1.5 / 3.0	1.5 / 3.8					1.5 / 3.0	1.5 / 3.0	1.5 / 3.0	1.5 / 3.0	1.5 / 3.8	2.2 / 5.6
26'	Live Load L/240			38	45	73					43	46	77	90	147	218
	Total Load			46	55	92					49	53	93	110	184	276
	End / Int. Bearing			1.5 / 3.0	1.5 / 3.0	1.5 / 3.2					1.5 / 3.0	1.5 / 3.0	1.5 / 3.0	1.5 / 3.0	1.5 / 3.2	1.9 / 4.8
28'	Live Load L/240					59							62	72	118	175
	Total Load					72							72	86	145	219
	End / Int. Bearing					1.5 / 3.0							1.5 / 3.0	1.5 / 3.0	1.5 / 3.0	1.7 / 4.1

### KEY TO TABLES

**Live Load L/240** = Maximum live load — limits deflection to L/240

**Total Load** = Maximum total load — limits deflection to L/180

**End/Int. Bearing** = Required minimum end bearing (inches) for simple or multiple span beams and minimum interior bearing (inches) for multiple span beams based on plate bearing stress of 565 psi.

See "Using Allowable Uniform Floor and Roof Load Tables," page 41.

# Allowable Uniform Roof Loads (PLF) – 125% (Non-Snow)

(Can be applied to the beam in addition to its own weight.)

## 1.5E GP Lam® LVL

Span	Condition	One 1 1/4" GP Lam LVL						Two 1 1/4" GP Lam LVL								
		7 1/4"	9 1/4"	9 1/2"	11 1/4"	11 1/2"	14"	4 3/4"	5 1/2"	7 1/4"	9 1/4"	9 1/2"	11 1/4"	11 1/2"	14"	16"
6'	Live Load L/240	742						419	687	1484						
	Total Load	860	1286	1330	1577	1577	1576	554	911	1719	2573	2661	3154	3153	3151	3150
	End / Int. Bearing	2.6 / 6.5	3.9 / 9.8	4.0 / 10.1	4.8 / 12.0	4.8 / 12.0	4.8 / 12.0	1.5 / 3.0	1.5 / 3.5	2.6 / 6.5	3.9 / 9.8	4.0 / 10.1	4.8 / 12.0	4.8 / 12.0	4.8 / 12.0	4.8 / 12.0
8'	Live Load L/240	333	658	708				181	301	665	1315	1415				
	Total Load	440	757	795	1087	1181	1180	238	396	881	1514	1590	2174	2362	2360	2359
	End / Int. Bearing	1.8 / 4.5	3.1 / 7.7	3.2 / 8.1	4.4 / 11.0	4.8 / 12.0	4.8 / 12.0	1.5 / 3.0	1.5 / 3.0	1.8 / 4.5	3.1 / 7.7	3.2 / 8.1	4.4 / 11.0	4.8 / 12.0	4.8 / 12.0	4.8 / 12.0
10'	Live Load L/240	175	353	380	610	708		94	157	351	705	760	1220	1415		
	Total Load	231	466	503	694	767	943	121	204	461	932	1005	1388	1534	1886	1884
	End / Int. Bearing	1.5 / 3.0	2.4 / 5.9	2.6 / 6.4	3.5 / 8.8	3.9 / 9.8	4.8 / 12.0	1.5 / 3.0	1.5 / 3.0	1.5 / 3.0	2.4 / 5.9	2.6 / 6.4	3.5 / 8.8	3.9 / 9.8	4.8 / 12.0	4.8 / 12.0
11'	Live Load L/240	133	269	290	468	544	855	71	118	266	538	580	936	1088	1709	
	Total Load	174	354	382	573	633	857	90	153	348	708	765	1145	1266	1713	1711
	End / Int. Bearing	1.5 / 3.0	2.0 / 5.0	2.2 / 5.4	3.2 / 8.0	3.6 / 8.9	4.8 / 12.0	1.5 / 3.0	1.5 / 3.0	1.5 / 3.0	2.0 / 5.0	2.2 / 5.4	3.2 / 8.0	3.6 / 8.9	4.8 / 12.0	4.8 / 12.0
12'	Live Load L/240	103	209	226	366	427	674	54	91	206	419	452	732	853	1348	
	Total Load	134	275	297	480	531	721	69	117	269	550	594	961	1062	1441	1568
	End / Int. Bearing	1.5 / 3.0	1.7 / 4.2	1.8 / 4.6	2.9 / 7.4	3.3 / 8.1	4.4 / 11.0	1.5 / 3.0	1.5 / 3.0	1.5 / 3.0	1.7 / 4.2	1.8 / 4.6	2.9 / 7.4	3.3 / 8.1	4.4 / 11.0	4.8 / 12.0
13'	Live Load L/240	81	166	179	292	340	540	43	72	163	332	359	583	680	1081	
	Total Load	105	217	235	384	448	613	53	91	211	435	470	768	897	1226	1446
	End / Int. Bearing	1.5 / 3.0	1.5 / 3.6	1.6 / 3.9	2.6 / 6.4	3.0 / 7.5	4.1 / 10.2	1.5 / 3.0	1.5 / 3.0	1.5 / 3.0	1.5 / 3.6	1.6 / 3.9	2.6 / 6.4	3.0 / 7.5	4.1 / 10.2	4.8 / 12.0
14'	Live Load L/240	65	134	145	236	276	439		58	131	268	290	472	551	879	1274
	Total Load	84	174	189	310	362	528		72	168	349	378	619	724	1056	1342
	End / Int. Bearing	1.5 / 3.0	1.5 / 3.2	1.5 / 3.4	2.2 / 5.6	2.6 / 6.5	3.8 / 9.5		1.5 / 3.0	1.5 / 3.0	1.5 / 3.2	1.5 / 3.4	2.2 / 5.6	2.6 / 6.5	3.8 / 9.5	4.8 / 12.0
15'	Live Load L/240	53	109	118	193	226	362		47	107	219	237	387	452	723	1052
	Total Load	68	142	154	253	296	459		58	136	284	307	506	592	918	1176
	End / Int. Bearing	1.5 / 3.0	1.5 / 3.0	1.5 / 3.0	2.0 / 4.9	2.3 / 5.7	3.5 / 8.8		1.5 / 3.0	1.5 / 3.0	1.5 / 3.0	1.5 / 3.0	2.0 / 4.9	2.3 / 5.7	3.5 / 8.8	4.5 / 11.3
16'	Live Load L/240	44	90	98	160	188	301		39	88	181	196	321	375	602	879
	Total Load	55	117	126	209	245	395		47	111	234	253	418	490	790	1032
	End / Int. Bearing	1.5 / 3.0	1.5 / 3.0	1.5 / 3.0	1.7 / 4.3	2.0 / 5.1	3.2 / 8.1		1.5 / 3.0	1.5 / 3.0	1.5 / 3.0	1.5 / 3.0	1.7 / 4.3	2.0 / 5.1	3.2 / 8.1	4.2 / 10.6
17'	Live Load L/240	37	76	82	134	157	253			74	152	164	269	315	506	741
	Total Load	46	97	105	174	205	331			92	194	210	349	409	663	913
	End / Int. Bearing	1.5 / 3.0	1.5 / 3.0	1.5 / 3.0	1.5 / 3.9	1.8 / 4.5	2.9 / 7.3			1.5 / 3.0	1.5 / 3.0	1.5 / 3.0	1.5 / 3.9	1.8 / 4.5	2.9 / 7.3	4.0 / 10.0
18'	Live Load L/240		64	69	114	133	215			62	128	139	228	267	430	630
	Total Load		81	88	147	172	280			76	163	177	294	345	560	812
	End / Int. Bearing		1.5 / 3.0	1.5 / 3.0	1.5 / 3.5	1.6 / 4.0	2.6 / 6.5			1.5 / 3.0	1.5 / 3.0	1.5 / 3.0	1.5 / 3.5	1.6 / 4.0	2.6 / 6.5	3.8 / 9.4
19'	Live Load L/240		54	59	97	114	184			53	109	118	194	228	368	540
	Total Load		68	74	124	146	239			64	137	149	249	293	478	705
	End / Int. Bearing		1.5 / 3.0	1.5 / 3.0	1.5 / 3.1	1.5 / 3.6	2.4 / 5.9			1.5 / 3.0	1.5 / 3.0	1.5 / 3.0	1.5 / 3.1	1.5 / 3.6	2.4 / 5.9	3.5 / 8.6
20'	Live Load L/240		47	50	83	98	158			45	94	101	167	196	317	466
	Total Load		58	63	106	125	205			54	117	127	213	251	410	607
	End / Int. Bearing		1.5 / 3.0	1.5 / 3.0	1.5 / 3.0	1.5 / 3.3	2.1 / 5.3			1.5 / 3.0	1.5 / 3.0	1.5 / 3.0	1.5 / 3.0	1.5 / 3.3	2.1 / 5.3	3.1 / 7.9
22'	Live Load L/240			38	63	74	120				71	76	126	148	240	354
	Total Load			47	79	93	154				86	94	158	187	308	458
	End / Int. Bearing			1.5 / 3.0	1.5 / 3.0	1.5 / 3.0	1.8 / 4.5				1.5 / 3.0	1.5 / 3.0	1.5 / 3.0	1.5 / 3.0	1.8 / 4.5	2.6 / 6.6
24'	Live Load L/240				49	57	93				54	59	98	115	186	275
	Total Load				60	71	118				64	70	120	142	236	352
	End / Int. Bearing				1.5 / 3.0	1.5 / 3.0	1.5 / 3.8				1.5 / 3.0	1.5 / 3.0	1.5 / 3.0	1.5 / 3.0	1.5 / 3.8	2.2 / 5.6
26'	Live Load L/240				38	45	73				43	46	77	90	147	218
	Total Load				46	55	92				49	53	93	110	184	276
	End / Int. Bearing				1.5 / 3.0	1.5 / 3.0	1.5 / 3.2				1.5 / 3.0	1.5 / 3.0	1.5 / 3.0	1.5 / 3.0	1.5 / 3.2	1.9 / 4.8
28'	Live Load L/240					59							62	72	118	175
	Total Load					72							72	86	145	219
	End / Int. Bearing					1.5 / 3.0							1.5 / 3.0	1.5 / 3.0	1.5 / 3.0	1.7 / 4.1

### KEY TO TABLES

**Live Load L/240** = Maximum live load — limits deflection to L/240

**Total Load** = Maximum total load — limits deflection to L/180

**End/Int. Bearing** = Required minimum end bearing (inches) for simple or multiple span beams and minimum interior bearing (inches) for multiple span beams based on plate bearing stress of 565 psi.

See "Using Allowable Uniform Floor and Roof Load Tables," page 41.

# Fastening Requirements

## GENERAL NOTES:

1. Confirm the adequacy of the beam (depth and thickness) for carrying the designated load.
2. Stress level for nail, bolt and screw values is 100%. Increases of 15% for snow loaded roof conditions or 25% for non-snow roof conditions are permitted.
3. Top and bottom rows of fasteners should be as shown in the fastener clearances detail. For staggered fastening patterns, the maximum end distance applies to all rows.
4. All fasteners must have the length fully embedded, but must not be over-driven, countersunk, or over-tightened.
5. Bolt holes are to be 1/2" to 1/8" diameter larger than the bolts. Bolts must meet or exceed ASTM A 307 or SAE J429 Grades 1 or 2. Every bolt must extend through the full thickness of the member. Use washers not less than a standard cut washer under the head and nut meeting ANSI B18.22.1.
6. 7" wide beams should only be side-loaded when loads are applied to both sides, when the lesser side load plf is at least 25% of the opposite side, or when the beam is otherwise restrained to minimize rotation.
7. For beam depths < 7/4", the maximum beam thickness must not exceed the beam depth and all fasteners must be staggered up to one-half the required o.c. spacing. For depths ≥ 7/4", the maximum beam thickness is 7".
8. Fastening recommendations are based on the 2005 National Design Specification for Wood Construction (NDS) or fastener manufacturer's design information.
9. SDS structural screws are produced by Simpson Strong-Tie Company, Inc., WS structural screws are produced by United Steel Products Company, and TrussLok structural screws are produced by FastenMaster-OMG, Inc. Structural screws must be installed per manufacturer's recommendations.

## Fastener Clearances for Multiple-Ply Members

Fastener	A	B		C		D
	Min.	Min.	Max.	Min.	Max.	Min.
10d & 16d Nails	2"	2"	6"	4"	12"	3"
Bolts & Screws	2"	4"	12"	4"	24"	3"

Spacings closer than those above may be acceptable, but require special consideration. Contact your technical representative.

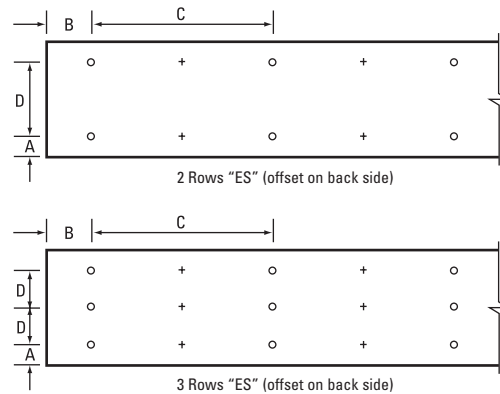

## Minimum Fastening Requirements for Top- and Side-Loaded Members

		3 1/2" Wide	5 1/4" Wide		7" Wide		
Fastener Type	LVL Depth	2-Ply 1 3/4"	3-Ply 1 3/4"	1 3/4" + 3 1/2"	4-Ply 1 3/4"	2-Ply 1 3/4" + 3 1/2"	2-Ply 3 1/2"
10d (0.128" x 3") Nails	7/4" ≤ d < 14"	3 rows @ 12" o.c.	3 rows @ 12" o.c. (ES)	3 rows @ 12" o.c.	-	3 rows @ 12" o.c. (ES)	-
	d ≥ 14"	4 rows @ 12" o.c.	4 rows @ 12" o.c. (ES)	4 rows @ 12" o.c.	-	4 rows @ 12" o.c. (ES)	-
16d (0.162" x 3 1/2") Nails	7/4" ≤ d < 14"	2 rows @ 12" o.c.	2 rows @ 12" o.c. (ES)	2 rows @ 12" o.c.	-	2 rows @ 12" o.c. (ES)	-
	d ≥ 14"	3 rows @ 12" o.c.	3 rows @ 12" o.c. (ES)	3 rows @ 12" o.c.	-	3 rows @ 12" o.c. (ES)	-
1/2" Through Bolts	d ≥ 7 1/4"	2 rows @ 24" o.c.	2 rows @ 24" o.c.		2 rows @ 24" o.c.		
SDS 1/4" x 3 1/2", WS35, 3 3/8" TrussLok		2 rows @ 24" o.c.	2 rows @ 24" o.c. (ES)	2 rows @ 24" o.c.	-	2 rows @ 24" o.c. (ES)	-
SDS 1/4" x 6", WS6		-	-		2 rows @ 24" o.c. (ES)		
5" TrussLok		-	2 rows @ 24" o.c.		-		
6 3/4" TrussLok		-	-		2 rows @ 24" o.c.		

## NOTES:

1. All fasteners must meet the minimum requirements in the table above. Side-loaded multiple-ply members must meet the minimum fastening and side-loading capacity requirements given on pages 52-53.
2. Minimum fastening requirements for depths less than 7/4" require special consideration. Please contact your technical representative.
3. Three general rules for staggering or offsetting for a certain fastener schedule: (1) if staggering or offsetting is not referenced, then none is required; (2) if staggering is referenced, then fasteners installed in adjacent rows on the front side are to be staggered up to one-half the o.c. spacing, but maintaining the fastener clearances above; and (3) if "ES" is referenced, then the fastener schedule must be repeated on **each side**, with the fasteners on the back side offset up to one-half the o.c. spacing of the front side (whether or not it is staggered).

## Top-Loaded

For required multiple-ply member fastening, only conditions where the loading is applied evenly across the top of all plies shall be considered "top-loaded." All other conditions must be fastened using the side-loaded recommendations on pages 52-53. All top-loaded multiple-ply LVL members must meet the **minimum fastener requirements** and required fastener spacing shown above.

## Fastening Requirements (continued)

### 2.0E GP Lam® LVL Side-Loaded

For required multiple-ply member fastening, conditions where the loading is not applied evenly across the top of all plies shall be considered side-loaded. All side-loaded multiple-ply members must meet the **minimum fastener requirements** on page 51 and the loading capacity requirements below.

### Maximum Uniform Load Applied to Either or Both Outside Plies (PLF)

Refer to General Notes page 51.

- Numbers in the table indicate load in pounds per lineal foot which may be applied to either side, except as shown in note 6 on page 51, based solely on the connection.
- Framing members must be attached with approved metal hangers. Refer to pages 28, 56 and 57 for hanger recommendations.
- This table applies to uniform loading only. Concentrated (point) side loads may require additional consideration.

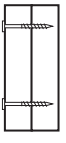
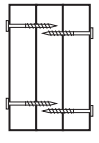
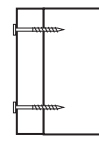
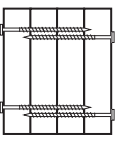
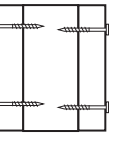
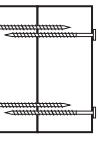
Fastener Schedule			3½" Wide	5¼" Wide		7" Wide		
Fastener Type	Number of Fastener Rows	Fastener On-Center Spacing (in.)						
			2-Ply 1¾"	3-Ply 1¾"	1¾" + 3½"	4-Ply 1¾"	2-Ply 1¾" + 3½"	2-Ply 3½"
10d (0.128" x 3") Nails	3	12	545	405 (ES)	405	—	360 (ES)	—
	4	12	725	545 (ES)	545	—	485 (ES)	—
16d (0.162" x 3½") Nails	2	12	565	425 (ES)	425	—	375 (ES)	—
	3	12	845	635 (ES)	635	—	563 (ES)	—
½" Through Bolts	2	24	505	380	525	340	465	860
		19.2	635	475	655	425	585	1075
		16	760	570	790	505	700	1290
SDS ¼" x 3½"	2	24	680	510 (ES)	510	—	455 (ES)	—
		19.2	850	640 (ES)	640	—	565 (ES)	—
		16	1020	765 (ES)	765	—	680 (ES)	—
SDS ¼" x 6"	2	24	—	—	—	555 (ES)	555 (ES)	680 (ES)
		19.2	—	—	—	695 (ES)	695 (ES)	850 (ES)
		16	—	—	—	835 (ES)	835 (ES)	1020 (ES)
USP WS35	2	24	500	375 (ES)	375	—	335 (ES)	—
		19.2	625	470 (ES)	470	—	415 (ES)	—
		16	750	565 (ES)	565	—	500 (ES)	—
USP WS6	2	24	—	—	—	335 (ES)	335 (ES)	500 (ES)
		19.2	—	—	—	415 (ES)	415 (ES)	625 (ES)
		16	—	—	—	500 (ES)	500 (ES)	750 (ES)
3¾" TrussLok	2	24	535	400 (ES)	400	—	355 (ES)	—
		19.2	670	500 (ES)	500	—	445 (ES)	—
		16	800	600 (ES)	600	—	535 (ES)	—
5" TrussLok	2	24	—	435	435	—	385 (ES)	580 (ES)
		19.2	—	545	545	—	485 (ES)	725 (ES)
		16	—	655	655	—	580 (ES)	870 (ES)
6¾" TrussLok	2	24	—	—	—	385	385	580
		19.2	—	—	—	485	485	725
		16	—	—	—	580	580	870

#### NOTES:

1. "ES" indicates fasteners must be installed from **each side** of the beam with the given fastening schedule. Stagger fasteners on opposite side of beam by up to one-half the required fastener on-center spacing.
2. For nails, tabulated values may be multiplied by 2.0 for 6" o.c. spacing and by 3.0 for 4" o.c. spacing. For bolts, tabulated values for 24" o.c. may be multiplied by 2.0 for 12" o.c. spacing. For structural screws, tabulated values for 24" o.c. may be multiplied by 2.0 for 12" o.c. spacing, by 4.0 for 6" o.c. spacing and by 6.0 for 4" o.c. spacing.
3. For 3 rows of fasteners, multiply tabulated values for 2 rows by 1.5. Center and stagger middle row by one-half the required o.c. spacing for depths less than 11¼".
4. Do not use fastener schedule if fastener clearances, required staggering and offsetting, or required fastening cannot be met. Consult technical representative for other options.

## Fastening Requirements (continued)

### 1.5E GP Lam® LVL Side-Loaded

For required multiple-ply member fastening, conditions where the loading is not applied evenly across the top of all plies shall be considered side-loaded. All side-loaded multiple-ply members must meet the **minimum fastener requirements** on page 51 and the loading capacity requirements below.

### Maximum Uniform Load Applied to Either or Both Outside Plies (PLF)

Refer to General Notes page 51.

- Numbers in the table indicate load in pounds per lineal foot which may be applied to either side, except as shown in note 6 on page 51, based solely on the connection.
- Framing members must be attached with approved metal hangers. Refer to pages 28, 56 and 57 for hanger recommendations.
- This table applies to uniform loading only. Concentrated (point) side loads may require additional consideration.

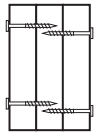
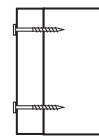
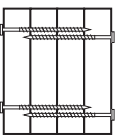
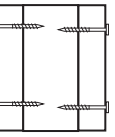
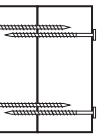
Fastener Schedule			3½" Wide	5¼" Wide		7" Wide		
Fastener Type	Number of Fastener Rows	Fastener On-Center Spacing (in.)						
			2-Ply 1¼"	3-Ply 1¼"	1¼" + 3½"	4-Ply 1¼"	2-Ply 1¼" + 3½"	2-Ply 3½"
10d (0.128" x 3") Nails	3	12	515	385 (ES)	385	—	340 (ES)	—
	4	12	685	515 (ES)	515	—	455 (ES)	—
16d (0.162" x 3½") Nails	2	12	530	400 (ES)	400	—	355 (ES)	—
	3	12	800	600 (ES)	600	—	530 (ES)	—
½" Through Bolts	2	24	420	315	450	280	400	780
		19.2	525	395	565	350	500	975
		16	630	475	675	420	600	1170
SDS ¼" x 3½"	2	24	515	385 (ES)	385	—	345 (ES)	—
		19.2	645	480 (ES)	480	—	430 (ES)	—
		16	770	580 (ES)	580	—	515 (ES)	—
SDS ¼" x 6"	2	24	—	—	—	420 (ES)	420 (ES)	515 (ES)
		19.2	—	—	—	525 (ES)	525 (ES)	645 (ES)
		16	—	—	—	630 (ES)	630 (ES)	770 (ES)
USP WS35	2	24	380	285 (ES)	285	—	250 (ES)	—
		19.2	475	355 (ES)	355	—	315 (ES)	—
		16	565	425 (ES)	425	—	380 (ES)	—
USP WS6	2	24	—	—	—	250 (ES)	250 (ES)	380 (ES)
		19.2	—	—	—	315 (ES)	315 (ES)	475 (ES)
		16	—	—	—	380 (ES)	380 (ES)	565 (ES)
3¾" TrussLok	2	24	405	305 (ES)	305	—	270 (ES)	—
		19.2	505	380 (ES)	380	—	335 (ES)	—
		16	605	455 (ES)	455	—	405 (ES)	—
5" TrussLok	2	24	—	330	330	—	295 (ES)	440 (ES)
		19.2	—	415	415	—	365 (ES)	550 (ES)
		16	—	495	495	—	440 (ES)	660 (ES)
6¾" TrussLok	2	24	—	—	—	295	295	440
		19.2	—	—	—	365	365	550
		16	—	—	—	440	440	660

#### NOTES:

1. "ES" indicates fasteners must be installed from **each side** of the beam with the given fastening schedule. Stagger fasteners on opposite side of beam by up to one-half the required fastener on-center spacing.
2. For nails, tabulated values may be multiplied by 2.0 for 6" o.c. spacing and by 3.0 for 4" o.c. spacing. For bolts, tabulated values for 24" o.c. may be multiplied by 2.0 for 12" o.c. spacing. For structural screws, tabulated values for 24" o.c. may be multiplied by 2.0 for 12" o.c. spacing, by 4.0 for 6" o.c. spacing and by 6.0 for 4" o.c. spacing.
3. For 3 rows of fasteners, multiply tabulated values for 2 rows by 1.5. Center and stagger middle row by one-half the required o.c. spacing for depths less than 11¼".
4. Do not use fastener schedule if fastener clearances, required staggering and offsetting, or required fastening cannot be met. Consult technical representative for other options.

# Tapered Cut Allowable End Reaction – Truss Roof

## 3 1/2" Thick GP Lam® LVL Beams Allowable End Reaction (lbs)

LVL Depth	Truss Chord Size	Beam Bearing Length	Truss Slope									
			4/12		6/12		8/12		10/12		12/12	
			D <sub>outside</sub> (inches)	Reaction (lbs)	D <sub>outside</sub> (inches)	Reaction (lbs)	D <sub>outside</sub> (inches)	Reaction (lbs)	D <sub>outside</sub> (inches)	Reaction (lbs)	D <sub>outside</sub> (inches)	Reaction (lbs)
7 1/4"	2x4	3 1/2" 5 1/4"	3 15/16	3395 3967	4 3/16	4419 4779	4 7/16	4790 Max.	4 13/16	Max. Max.	5 3/16	Max. Max.
	2x6	3 1/2" 5 1/4"	6 1/16	4821 Max.	6 3/8	Max. Max.	6 7/8	Max. Max.	7 1/4	Max. Max.	7 1/4	Max. Max.
9 1/4" or 9 1/2"	2x4	3 1/2" 5 1/4"	3 15/16	3395 3783	4 3/16	3932 4877	4 7/16	5238 5941	4 13/16	5910 6151	5 3/16	6128 Max.
	2x6	3 1/2" 5 1/4"	6 1/16	4873 5576	6 3/8	5953 6144	6 7/8	6151 Max.	7 1/16	Max. Max.	8	Max. Max.
11 1/4" or 11 7/8"	2x4	3 1/2" 5 1/4"	3 15/16	— —	4 3/16	3932 4514	4 7/16	4515 5972	4 13/16	6115 7109	5 3/16	6921 7440
	2x6	3 1/2" 5 1/4"	6 1/16	4797 5185	6 3/8	5631 6699	6 7/8	6921 7405	7 7/16	6921 7481	8	6921 Max.
14"	2x4	3 1/2" 5 1/4"	3 15/16	— —	4 3/16	— —	4 7/16	— —	4 13/16	5238 7291	5 3/16	6921 8508
	2x6	3 1/2" 5 1/4"	6 1/16	4797 5185	6 3/8	5419 6001	6 7/8	6803 8034	7 7/16	6921 8978	8	6921 9284
16"	2x6	3 1/2" 5 1/4"	6 1/16	4797 5185	6 3/8	5419 6001	6 7/8	6114 7577	7 7/16	6921 9437	8	6921 10269
18"	2x6	3 1/2" 5 1/4"	6 1/16	4797 5185	6 3/8	5419 6001	6 7/8	6114 6890	7 7/16	6921 9354	8	6921 10382
24"	2x6	3 1/2" 5 1/4"	6 1/16	— —	6 3/8	— —	6 7/8	— —	7 7/16	— —	8	6921 10203

**NOTES:**

- Prior to using this table, beam size must be checked by tables or FASTBeam® software.
- Table can also be used for 1 3/4", 5 1/4" and 7" thick GP Lam LVL beams  
For 1 3/4" thick beam: 0.5 x allowable reaction (lbs)  
For 5 1/4" thick beam: 1.5 x allowable reaction (lbs)  
For 7" thick beam: 2.0 x allowable reaction (lbs)
- Provide lateral support at bearing points, and continuous lateral support along top (or compression edge) of beam.
- Listed values are for 1.5E and 2.0E GP Lam LVL beam products.
- Special consideration is required for uplift reactions.
- Concentrated loads, holes, and other notches are not allowed in the tapered cut region.
- Southern Pine bearing plate assumed (565 psi).
- Values are for floor use, 100% duration of load increase.
- If "Max." is shown in Reaction column, full capacity is available.
- If no allowable reaction is shown, beam will not work with current input; try using a shallower beam with additional plies.
- Field verify slope and all dimensions.
- 1/4" butt cut height assumed for truss bottom chord.

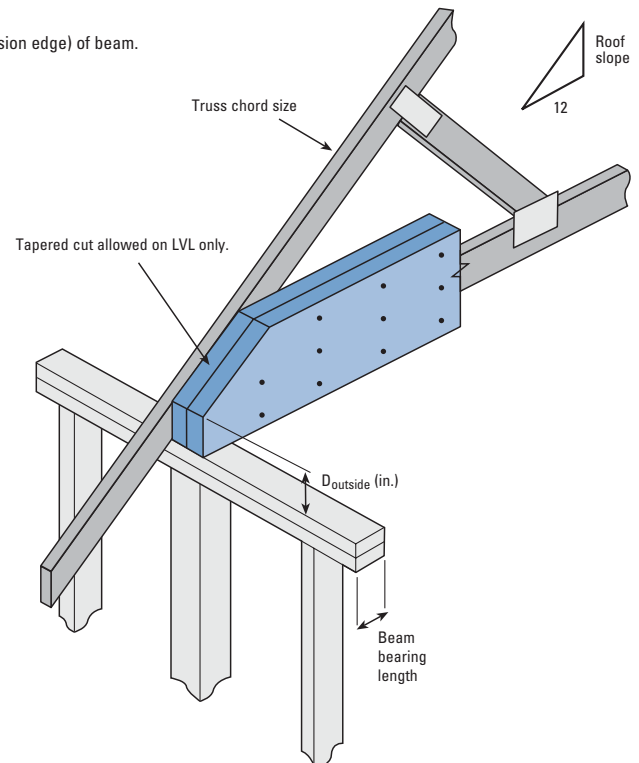

# Tapered Cut Allowable End Reaction – Conventional (Stick) Roof

## 3 1/2" Thick GP Lam® LVL Beams Allowable End Reaction (lbs)

LVL Depth	Rafter Size	Beam Bearing Length	Rafter Slope									
			4/12		6/12		8/12		10/12		12/12	
			D <sub>outside</sub> (inches)	Reaction (lbs)	D <sub>outside</sub> (inches)	Reaction (lbs)	D <sub>outside</sub> (inches)	Reaction (lbs)	D <sub>outside</sub> (inches)	Reaction (lbs)	D <sub>outside</sub> (inches)	Reaction (lbs)
7 1/4"	2x6	3 1/2"	4 3/8	4095	4 3/8	4559	4 1/4	4759	4 1/4	4820	4 1/4	Max.
		5 1/4"	4 1/16	4095	3 1/2	4559	3 3/8	4759	2 13/16	4820	2 1/2	Max.
	2x8	3 1/2"	6 1/2	Max.	6 3/8	Max.	6 3/8	Max.	6 1/2	Max.	6 3/4	Max.
		5 1/4"	5 7/8	Max.	5 1/2	Max.	5 3/16	Max.	5 1/16	Max.	5	Max.
9 1/4" or 9 1/2"	2x6	3 1/2"	4 3/8	3855	4 3/8	4089	4 1/4	5057	4 1/4	5664	4 1/4	5966
		5 1/4"	4 1/16	3855	3 1/2	4089	3 3/8	—	2 13/16	—	2 1/2	—
	2x8	3 1/2"	6 1/2	5416	6 3/8	5936	6 3/8	6118	6 1/2	6151	6 3/4	Max.
		5 1/4"	5 7/8	5416	5 1/2	5936	5 3/16	6118	5 1/16	6151	5	Max.
	2x10	3 1/2"	8 9/16	Max.	8 3/16	Max.	8 13/16	Max.	9 1/8	Max.	9 1/4	Max.
		5 1/4"	8	Max.	7 11/16	Max.	7 5/8	Max.	7 11/16	Max.	7 13/16	Max.
11 1/4" or 11 7/8"	2x6	3 1/2"	4 5/8	3855	4 3/8	4089	4 1/4	4396	4 1/4	5418	4 1/4	6451
		5 1/4"	4 1/16	3855	3 1/2	—	3 3/8	—	2 13/16	—	2 1/2	—
	2x8	3 1/2"	6 1/2	5082	6 3/8	5566	6 3/8	6745	6 1/2	6921	6 3/4	6921
		5 1/4"	5 7/8	5082	5 1/2	5566	5 3/16	6745	5 1/16	7203	5	7417
	2x10	3 1/2"	8 9/16	6921	8 3/16	6921	8 13/16	6921	9 1/8	Max.	9 9/16	Max.
		5 1/4"	8	6973	7 11/16	7375	7 5/8	7480	7 11/16	Max.	7 13/16	Max.
2x12	3 1/2"	10 11/16	6921	10 13/16	Max.	11 3/16	Max.	11 1/4	Max.	11 1/4	Max.	
	5 1/4"	10 1/8	7481	9 15/16	Max.	10	Max.	10 1/4	Max.	10 11/16	Max.	
14"	2x8	3 1/2"	6 1/2	5082	6 3/8	5390	6 3/8	6111	6 1/2	6921	6 3/4	6921
		5 1/4"	5 7/8	5082	5 1/2	5390	5 3/16	6111	5 1/16	7550	5	8399
	2x10	3 1/2"	8 9/16	6484	8 3/16	6921	8 13/16	6921	9 1/8	6921	9 9/16	6921
		5 1/4"	8	6484	7 11/16	7589	7 5/8	8564	7 11/16	9056	7 13/16	9267
2x12	3 1/2"	10 11/16	6921	10 13/16	6921	11 3/16	6921	11 3/4	Max.	12 1/16	Max.	
	5 1/4"	10 1/8	8539	9 15/16	9096	10	9293	10 1/4	Max.	10 11/16	Max.	
16"	2x8	3 1/2"	6 1/2	5082	6 3/8	5390	6 3/8	5794	6 1/2	6921	6 3/4	6921
		5 1/4"	5 7/8	5082	5 1/2	5390	5 3/16	—	5 1/16	—	5	—
	2x10	3 1/2"	8 9/16	6484	8 3/16	6877	8 13/16	6921	9 1/8	6921	9 9/16	6921
		5 1/4"	8	6484	7 11/16	6877	7 5/8	8501	7 11/16	9601	7 13/16	10207
2x12	3 1/2"	10 11/16	6921	10 13/16	6921	11 3/16	6921	11 3/4	6921	12 1/16	6921	
	5 1/4"	10 1/8	7886	9 15/16	9402	10	10187	10 1/4	10382	10 11/16	10382	
18"	2x8	3 1/2"	6 1/2	5082	6 3/8	5390	6 3/8	5794	6 1/2	6276	6 3/4	6921
		5 1/4"	5 7/8	—	5 1/2	—	5 3/16	—	5 1/16	—	5	—
	2x10	3 1/2"	8 9/16	6484	8 3/16	6877	8 13/16	6921	9 1/8	6921	9 9/16	6921
		5 1/4"	8	6484	7 11/16	6877	7 5/8	7719	7 11/16	9616	7 13/16	10382
2x12	3 1/2"	10 11/16	6921	10 13/16	6921	11 3/16	6921	11 3/4	6921	12 1/16	6921	
	5 1/4"	10 1/8	7886	9 15/16	8861	10	10382	10 1/4	10382	10 11/16	10382	
24"	2x10	3 1/2"	8 9/16	6484	8 3/16	6877	8 13/16	6921	9 1/8	6921	9 9/16	6921
		5 1/4"	8	6484	7 11/16	—	7 5/8	—	7 11/16	—	7 13/16	—
2x12	3 1/2"	10 11/16	6921	10 13/16	6921	11 3/16	6921	11 3/4	6921	12 1/16	6921	
	5 1/4"	10 1/8	7886	9 15/16	8364	10	8991	10 1/4	10382	10 11/16	10382	

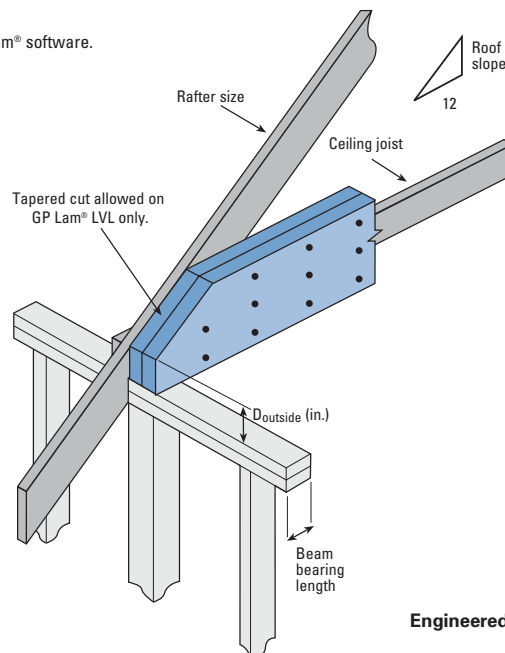

### NOTES:

- Prior to using this table, beam size must be checked by tables or FASTBeam® software.
- Table can also be used for 1 3/4", 5 1/4" and 7" thick GP Lam LVL beams  
 For 1 3/4" thick beam: 0.5 x allowable reaction (lbs)  
 For 5 1/4" thick beam: 1.5 x allowable reaction (lbs)  
 For 7" thick beam: 2.0 x allowable reaction (lbs)
- Provide lateral support at bearing points, and continuous lateral support along top (or compression edge) of beam.
- Listed values are for 1.5E and 2.0E GP Lam LVL beam products.
- Special consideration is required for uplift reactions.
- Concentrated loads, holes, and other notches are not allowed in the tapered cut region.
- Southern Pine bearing plate assumed (565 psi).
- Values are for floor use, 100% duration of load increase.
- If "Max." is shown in Reaction column, full capacity is available.
- If no allowable reaction is shown, beam will not work with current input; try using a shallower beam with additional plies.
- Field verify slope and all dimensions.



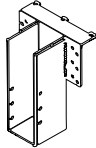

## USP Structural Connectors™ for GP Lam® LVL

GP Lam LVL Member Supported		Top Mount	Capacity 100% (lbs)	Face Mount	Capacity 100% (lbs)
Thickness	Beam Depth				
1 3/4"	7 1/4"	PHXU17725	4425	HD1770	1960
	9 1/4"	BPH17925	3395	THD179	5320
	9 1/2"	BPH1795	3395	THD179	5320
	11 1/4"	BPH17112	3395	THD179	5320
	11 1/8"	BPH17118	3395	THD179	5320
	14"	BPH1714	3395	THD179	5320
3 1/2"	7 1/4"	—	—	—	—
	9 1/4"	LBH35925	6500	THDH410	8170
	9 1/2"	LBH3595	6500	THDH410	8170
	11 1/4"	LBH35112	6500	THDH412	9875
	11 1/8"	LBH35118	6500	THDH412	9875
	14"	HLBH3514	10620	THDH414	11100
	16"	HLBH3516	10620	THDH414	11100
	18"	HLBH3518	10620	THDH414	11100
5 1/4"	7 1/4"	—	—	—	—
	9 1/4"	HLBH52925	10620	THDH610	8640
	9 1/2"	HLBH5295	10620	THDH610	8640
	11 1/4"	HLBH52112	10620	THDH612	9935
	11 1/8"	HLBH52118	10620	THDH612	9935
	14"	HLBH5214	10620	THDH614	11645
	16"	HLBH5216	10620	THDH614	11645
	18"	HLBH5218	10620	THDH614	11645
7"	9 1/4"	HLBH71925	10620	THDH7210	8170
	9 1/2"	HLBH7195	10620	THDH7210	8170
	11 1/4"	HLBH71112	10620	THDH7212	9875
	11 1/8"	HLBH71118	10620	THDH7212	9875
	14"	HLBH7114	10620	THDH7214	11580
	16"	HLBH7116	10620	THDH7214	11580
	18"	HLBH7118	10620	THDH7214	11580
	24"	HLBH7124	10620	—	—

### USP Beam-To-Column Connectors for GP Lam LVL

Column Cap	Capacity* 100% (lbs)	W1	Column **	W2	L	H
KCC44	15315	3 3/8"	4 x __Wood	3 3/8"	7"	4"
KCC46	24065	3 3/8"	6 x __Wood	5 1/2"	11"	6 1/2"
KCC48	24065	3 3/8"	8 x __Wood	7 1/2"	11"	6 1/2"
KCC64	37815	5 1/2"	4 x __Wood	3 3/8"	11"	6 1/2"
KCC66	37815	5 1/2"	6 x __Wood	5 1/2"	11"	6 1/2"
KCC68	37815	5 1/2"	8 x __Wood	7 1/2"	11"	6 1/2"
KCC84	60940	7 1/2"	4 x __Wood	3 3/8"	13"	8"
KCC86	60940	7 1/2"	6 x __Wood	5 1/2"	13"	8"
KCC88	60940	7 1/2"	8 x __Wood	7 1/2"	13"	8"
KLCC35-4	21000	3 3/8"	4" dia. steel	—	11 1/2"	4"
KLCC525-4	21000	5 3/8"	4" dia. steel	—	11 1/2"	4"
KLCC7-4	21000	7 3/8"	4" dia. steel	—	11 1/2"	4"

\* Capacity is maximum capacity of the USP column cap.  
\*\* Adequacy of column to be verified by others.

#### NOTES:

- Capacity is for the stated duration of load—100% floor loading. Hanger capacity depends on the hanger selected, quantity and size of nails used, and the size and type of support to which it is fastened. **Hanger capacities shown are based on attachment to LVL header material using the hanger manufacturer's recommended nailing. Minimum header thickness is 3 1/2".** Some hanger/header/fastener combinations may not meet maximum beam capacities and a qualified designer should be consulted. Before selecting hangers, please refer to the appropriate reference/design guide from the hanger manufacturer for expanded design information. Many other designs are available for specialized applications.
- Hanger model numbers quoted are for United Steel Products Company, Inc. and Simpson Strong-Tie® hangers. Some suppliers carry similar products produced by other manufacturers. Contact your local building material retailer or Georgia-Pacific for conversion information and details.
- Special consideration is required with top mount hangers on nailers. Refer to the hanger manufacturer's catalog for reduced capacity.

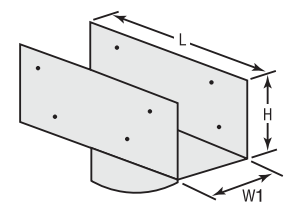
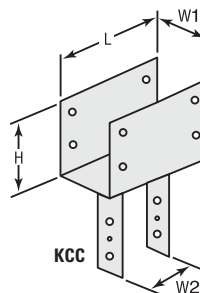

# Simpson Strong-Tie® Connectors for GP Lam® LVL

Refer to notes on page 56.

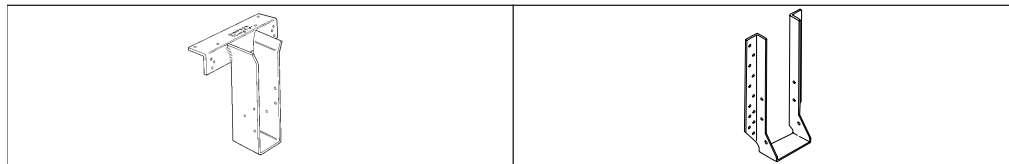

GP Lam LVL Member Supported		Top Mount	Capacity 100% (lbs)	Face Mount	Capacity 100% (lbs)
Thickness	Beam Depth				
1 3/4"	7 1/4"	WP1.81/7.25	3635	HU7	2145
	9 1/4"	WP9.25	3635	HUS1.81/10	4900
	9 1/2"	WP9	3635	HUS1.81/10	4900
	11 1/4"	LBV1.81/11.25	2910	HUS1.81/10	4900
	11 7/8"	WP11	3635	HUS1.81/10	4900
	14"	WP14	3635	HUS1.81/10	4900
3 1/2"	7 1/4"	WPU3.56/7.25	4700	HGUS48	6805
	9 1/4"	HWU3.56/9.25	6335	HGUS410	8780
	9 1/2"	HWU3.56/9.5	6335	HGUS410	8780
	11 1/4"	HWU3.56/11.25	6335	HGUS412	9155
	11 7/8"	HWU3.56/11.88	6335	HGUS412	9155
	14"	HWU3.56/14	6335	HGUS414	10015
	16"	HWU3.56/16	6335	HGUS414	10015
	18"	HWU3.56/18	6335	HGUS414	10015
5 1/4"	7 1/4"	WPU5.50/7.25	4700	—	—
	9 1/4"	GLTV5.50/9.25	7500	HGUS5.50/10	8780
	9 1/2"	HGLTV5.59	10500	HGUS5.50/10	8780
	11 1/4"	GLTV5.50/11.25	7500	HGUS5.50/12	9155
	11 7/8"	HGLTV5.511	10500	HGUS5.50/12	9155
	14"	HGLTV5.514	10500	HGUS5.50/14	10015
	16"	HGLTV5.516	10500	HGUS5.50/14	10015
	18"	HGLTV5.518	10500	HGUS5.50/14	10015
7"	9 1/4"	GLTV49.25-2	7500	HGUS7.25/10	8780
	9 1/2"	GLTV49.5-2	7500	HGUS7.25/10	8780
	11 1/4"	GLTV411.25-2	7500	HGUS7.25/12	9835
	11 7/8"	HGLTV411.88-2	10500	HGUS7.25/12	9835
	14"	HGLTV414-2	10500	HGUS7.25/14	11110
	16"	HGLTV416-2	10500	HGUS7.25/14	11110
	18"	HGLTV418-2	10500	HGUS7.25/14	11110
	24"	HGLTV7.12/24	10500	—	—

## Simpson Beam-To-Column Connectors for GP Lam LVL

Column Cap	Capacity* 100% (lbs)	W1	Column**	W2	L	H
CC44	15310	3 5/8"	4 x __Wood	3 5/8"	7"	4"
CC46	24060	3 5/8"	6 x __Wood	5 1/2"	11"	6 1/2"
CC48	24060	3 5/8"	8 x __Wood	7 1/2"	11"	6 1/2"
CC64	28586	5 1/2"	4 x __Wood	3 5/8"	11"	6 1/2"
CC66	30250	5 1/2"	6 x __Wood	5 1/2"	11"	6 1/2"
CC68	37810	5 1/2"	8 x __Wood	7 1/2"	11"	6 1/2"
CC86	41250	7 1/2"	6 x __Wood	5 1/2"	13"	8"
CC88	54600	7 1/2"	8 x __Wood	7 1/2"	13"	8"
LCC3.5-4	20670	3 5/8"	4" dia. steel	—	11 1/2"	4"
LCC5.25-4	20670	5 3/8"	4" dia. steel	—	11 1/2"	4"
LCC7-4	20670	7 3/8"	4" dia. steel	—	11 1/2"	4"

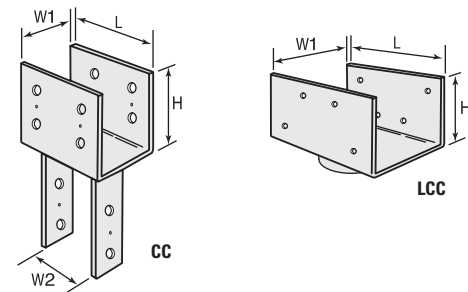

\* Capacity is maximum capacity of the Simpson column cap.

\*\* Adequacy of column to be verified by others.

# GP Lam® LVL Beam and Header Design Properties

## 1<sup>3</sup>/<sub>4</sub>" 2.0E GP Lam LVL Allowable Edgewise Design Properties<sup>a</sup>

Depth <sup>b</sup>	EI (10 <sup>6</sup> inch <sup>2</sup> lbs)	Maximum Resistive Moment (ft-lbs)			Maximum Vertical Shear (lbs)			Weight (lbs/ft)
		100%	115%	125%	100%	115%	125%	
7 1/4"	111	3918	4506	4898	2411	2772	3013	3.4
9 1/4"	231	6208	7139	7760	3076	3537	3845	4.4
9 1/2"	250	6529	7508	8161	3159	3633	3948	4.5
11 1/4"	415	8985	10333	11231	3741	4302	4676	5.3
11 1/8"	488	9951	11444	12439	3948	4541	4936	5.6
14"	800	13581	15618	16976	4655	5353	5819	6.6
16"	1195	17477	20098	21846	5320	6118	6650	7.6
18"	1701	21831	25106	27289	5985	6883	7481	8.5
24"	4032	37591	43229	46988	7980	9177	9975	11.4

a. Table assumes beam has lateral support at bearing points and continuous lateral support along the compression edge of the beam.

b. 1<sup>3</sup>/<sub>4</sub>" beams deeper than 14" must only be used in multiple-ply members.

## 1<sup>3</sup>/<sub>4</sub>" 1.5E GP Lam LVL Allowable Edgewise Design Properties<sup>a</sup>

Depth <sup>b</sup>	EI (10 <sup>6</sup> inch <sup>2</sup> lbs)	Maximum Resistive Moment (ft-lbs)			Maximum Vertical Shear (lbs)			Weight (lbs/ft)
		100%	115%	125%	100%	115%	125%	
7 1/4"	83	3106	3572	3883	2411	2772	3013	3.3
9 1/4"	173	4870	5601	6088	3076	3537	3845	4.2
9 1/2"	188	5116	5884	6395	3159	3633	3948	4.3
11 1/4"	311	6990	8039	8738	3741	4302	4676	5.1
11 1/8"	366	7724	8883	9655	3948	4541	4936	5.3
14"	600	10468	12038	13084	4655	5353	5819	6.3
16"	896	13394	15403	16742	5320	6118	6650	7.2

a. Table assumes beam has lateral support at bearing points and continuous lateral support along the compression edge of the beam.

b. 1<sup>3</sup>/<sub>4</sub>" beams deeper than 14" must only be used in multiple-ply members.

## 2.0E GP Lam Allowable Edgewise Design Stresses<sup>1</sup>

Modulus of Elasticity	E = 2.0 x 10 <sup>6</sup> psi <sup>2</sup>
Shear Modulus of Elasticity	G = 125,000 psi
Flexural Stress	F <sub>b</sub> = 2,900 psi <sup>3</sup>
Horizontal Shear	F <sub>v</sub> = 285 psi
Compression Perpendicular to Grain	F <sub>c⊥</sub> = 845 psi <sup>2</sup>
Compression Parallel to Grain	F <sub>c∥</sub> = 2,600 psi
Equivalent Specific Gravity	SG = 0.50

## 1.5E GP Lam Allowable Edgewise Design Stresses<sup>1</sup>

Modulus of Elasticity	E = 1.5 x 10 <sup>6</sup> psi <sup>2</sup>
Shear Modulus of Elasticity	G = 93,750 psi
Flexural Stress	F <sub>b</sub> = 2,250 psi <sup>3</sup>
Horizontal Shear	F <sub>v</sub> = 285 psi
Compression Perpendicular to Grain	F <sub>c⊥</sub> = 750 psi <sup>2</sup>
Compression Parallel to Grain	F <sub>c∥</sub> = 2,200 psi
Equivalent Specific Gravity	SG = 0.43

1. Allowable design stresses apply to depths as small as 3 1/2" ripped from any depth of beam.

2. No increase is allowed to E, G or F<sub>c⊥</sub> for duration of load.

3. For depths (d) other than 12" multiply F<sub>b</sub> by (12/d)<sup>1/9</sup> for 2.0E, and (12/d)<sup>1/6.5</sup> for 1.5E.

# GP Lam<sup>®</sup> LVL Architectural Specifications

## Part 1—General

### 1.0—Description

- A. Work in this section includes, but is not limited to:  
Laminated Veneer Lumber (LVL) beams and headers.
- B. Related work specified elsewhere:  
Rough carpentry.

### 1.1—Submittals:

- A. Product data:  
Submit manufacturer's descriptive literature indicating material composition, thicknesses, dimensions, loading and fabrication details.
- B. Shop drawings:  
Submit manufacturer's literature indicating installation details. Include locations and details of bearing, blocking, bridging and cutting for work by others.

### 1.2—Quality Assurance:

- A. Certification:  
All GP Lam<sup>®</sup> LVL has been qualified to ASTM D 5456 by APA-The Engineered Wood Association.

### 1.3—Delivery, Storage and Handling:

- A. Delivery:  
Deliver materials to the job site in manufacturer's original packaging, containers and bundles with manufacturer's identification intact and legible.
- B. Storage and handling:  
Store and handle materials to protect against contact with damp and wet surfaces, exposure to weather, breakage and damage. Provide air circulation under covering and around stacks of materials.

### 1.4—Limitations:

- A. Cutting:  
Except for cutting to length, GP Lam LVL beams and headers shall not be cut, drilled or notched, except as noted in manufacturer's literature.
- B. Moisture conditions:  
GP Lam LVL is for use in covered, dry-use conditions only (moisture content less than 16%).

## Part 2—Products

### 2.0—Prefabricated wood beams and headers:

- A. Acceptable products: 2.0E, 1.5E
  1. Georgia-Pacific, GP Lam LVL floor and roof beams.
  2. Georgia-Pacific, GP Lam LVL window and door headers.
- B. Characteristics:
  1. Construction:  
1 $\frac{3}{8}$ " and 3 $\frac{1}{2}$ " thick pressure bonded, lap-jointed wood veneers, with grain of veneers running parallel in the long direction.
  2. Standard beam depths:  
2.0E—1 $\frac{3}{4}$ " and 3 $\frac{1}{2}$ " thickness: 7 $\frac{1}{4}$ ", 9 $\frac{1}{4}$ ", 9 $\frac{1}{2}$ ", 11 $\frac{1}{4}$ ", 11 $\frac{7}{8}$ ", 14", 16", 18", 24" (20" and 22" by special order)  
1.5E—1 $\frac{3}{4}$ " thickness: 7 $\frac{1}{4}$ ", 9 $\frac{1}{4}$ ", 9 $\frac{1}{2}$ ", 11 $\frac{1}{4}$ ", 11 $\frac{7}{8}$ ", 14", 16"  
1.5E—3 $\frac{1}{2}$ " thickness: 4 $\frac{5}{8}$ ", 5 $\frac{1}{2}$ ", 7 $\frac{1}{4}$ ", 9 $\frac{1}{4}$ ", 9 $\frac{1}{2}$ ", 11 $\frac{1}{4}$ ", 11 $\frac{7}{8}$ ", 14", 16"  
As required for loading, deflection and span.
  3. Beam length:  
As required for span and bearing.

### 2.1—Accessories:

- A. Fasteners:  
16d common nails, approved structural screws or  $\frac{1}{2}$ " bolts.
- B. Hangers:  
1. Contact GP or an engineer for acceptable connectors.

## Part 3—Execution

### 3.0—General:

- A. Provide GP Lam LVL beams and headers where indicated on drawings using hangers and accessories specified.
- B. Install GP Lam LVL beams and headers in accordance with manufacturer's recommendations.

### 3.1—Accessories:

Install accessories where indicated and in accordance with beam and header manufacturer's instructions.

# ENGINEERED FOR PERFORMANCE

What you don't see matters.™  
Build it better.®



When it comes to floor joists, rim board, beams and headers, builders and contractors choose Georgia-Pacific engineered lumber for many reasons. Today's residential building trends call for large, open spaces and high ceilings, creating a demand for products that provide higher strength and greater stability over longer spans.

Georgia-Pacific engineered lumber provides the following benefits:

- More open spaces
- Quieter floors
- A flat, level, more stable floor system
- Lifetime limited warranty\*

For more information, call 877-437-9759 or visit [www.gp.com/build](http://www.gp.com/build).

## SALES, UPDATES AND CURRENT INFORMATION

The sale of our engineered lumber products is subject to our terms of sale which are available at [www.gp.com/tc](http://www.gp.com/tc) or upon request. The information in this document may change without notice. Visit our website at [www.gp.com/build](http://www.gp.com/build) for updates and current information or call 800-284-5347 to request a current copy.

## GENERAL

The user is responsible for proper installation of our engineered lumber products. Our engineered lumber products must be installed in strict conformity with our instructions and all applicable building code requirements and other regulations. In addition, if not specifically covered by our installation instructions or construction detail illustrations, the products must be installed in accordance with generally accepted design and construction practices. When installing engineered lumber products, the user must also consider the effects of local climate and geography. We do not warrant and are not responsible for the design and construction of any finished structure or system into which our engineered lumber products may be incorporated or other building components that may be used with our products.

## LIMITATION OF REMEDIES AND DAMAGES

EXCEPT AS EXPRESSLY STATED IN OUR LIFETIME LIMITED WARRANTY, WE DO NOT MAKE AND HEREBY EXPRESSLY DISCLAIM, ANY AND ALL OTHER REPRESENTATIONS AND WARRANTIES OF ANY KIND WHATSOEVER, EXPRESS OR IMPLIED, INCLUDING BUT NOT LIMITED TO WARRANTIES OF OR AS TO MERCHANTABILITY OR FITNESS FOR A PARTICULAR PURPOSE. THE EXCLUSIVE REMEDIES FOR BREACH OF WARRANTY, AND AT GP'S SOLE OPTION, ARE REPAIR OF AFFECTED PRODUCT, REPLACEMENT OF AFFECTED PRODUCT OR REIMBURSEMENT OF THE REASONABLE COST OF REPAIR OR REPLACEMENT OF THE AFFECTED PRODUCT. WE SHALL NOT BE RESPONSIBLE UNDER ANY CIRCUMSTANCES FOR LOST PROFITS, DAMAGE TO A STRUCTURE IN WHICH THE AFFECTED PRODUCT IS INSTALLED, DAMAGE TO OTHER PROPERTY, LOSS OF USE OF THE PRODUCT OR OTHER PROPERTY OR ANY OTHER INDIRECT, INCIDENTAL, EXEMPLARY, SPECIAL, CONSEQUENTIAL OR PUNITIVE DAMAGES. IN NO EVENT, REGARDLESS OF THE FORM OF THE CLAIM OR CAUSE OF ACTION, OUR CUMULATIVE LIABILITY TO BUYER SHALL NOT EXCEED THE PURCHASE PRICE FOR THE SPECIFIC PRODUCT GIVING RISE TO THE CLAIM OR CAUSE OF ACTION. WARRANTY CLAIMS SHALL BE

DEEMED WAIVED IF THEY ARE NOT SUBMITTED TO US IN WRITING WITHIN THIRTY (30) DAYS AFTER DISCOVERY. OUR ENGINEERED LUMBER PRODUCTS MAY SUPPORT MOLD GROWTH IF EXPOSED TO CERTAIN CONDITIONS, INCLUDING MOISTURE, DAMPNES, CONDENSATION, HUMIDITY, WATER OR WET CONDITIONS. MOLD, MILDEW, FUNGI, ALGAE, MOSS, BACTERIAL GROWTH, DECAY, ROT OR SIMILAR CONDITIONS ARE NOT MANUFACTURING OR PRODUCT DEFECTS AND WE ASSUME NO RESPONSIBILITY OR LIABILITY FOR SUCH CONDITIONS, REGARDLESS OF CAUSE.

## HEALTH AND SAFETY CAUTION

Georgia-Pacific engineered lumber products are manufactured with one or more of the following adhesives: phenol-formaldehyde, phenol-resorcinol-formaldehyde, melamine and/or polyurethane. Formaldehyde emissions from products with these adhesives are considered close to background levels and current regulations do not generally require emission measurements. A Material Safety Data Sheet (MSDS) containing potential physical and health hazard information is available from your employer or by contacting the Products Safety and Health Information Department at Georgia-Pacific LLC, P.O. Box 105605, Atlanta, GA 30348-5605, 404-652-5119 or visit [www.gp.com/build](http://www.gp.com/build).



Georgia-Pacific Wood Products LLC  
133 Peachtree Street, 14th Floor  
Atlanta, GA 30303  
877-437-9759

\* See manufacturer's warranty for terms, conditions and limitations ([www.gp.com/build](http://www.gp.com/build)).

Georgia-Pacific, GP, the GP logo, Wood I Beam logo, Wood I Beam, GP Lam, FiberStrong, What you don't see matters, and Build It Better are owned by or licensed to Georgia-Pacific Wood Products LLC.

©2012 Georgia-Pacific Wood Products LLC. All rights reserved. Printed in the U.S.A. 3/12 GEO-TM Lit. Item #123040 (pgs. 32-59)