



Building Product Evaluation Report 0142

MoistureShield Guardrail Systems MoistureShield, Inc.

Initial Acceptance: May 11, 2023

Expiration: May 11, 2024

TYPE OF ACCEPTANCE

Product Material – Wood and Plastics

CSI Specification Division: 06 50 00 (Structural Plastic) and 06 63 00 (Plastic Railing)

MANUFACTURER IDENTIFICATION:

MoistureShield, Inc

810 Jefferson Street
Springdale, AR 72764
1-479-756-7400

www.moistureshield.com

EVALUATION REPORT SUBJECT:

Navigator, Traverse, and Discovery Guardrail Systems for Exterior Applications. Installation on construction complying with the International Residential Code® (IRC®) or with the International Building Code® (IBC®), including IBC exceptions in Section 1015.3 of the IBC.

DESCRIPTION OF BUILDING COMPONENTS:

MoistureShield guardrail systems are identified by the names – **Navigator, Traverse, and Discovery (Guardrail) Systems**. The guardrail systems are for use in areas as referenced in the Applicable Codes. The guardrail systems provide a protective barrier for walking areas, balconies, porches, stairs, and ramps. The guardrail systems are manufactured by the co-extrusion process, assembled with molded components, and are produced in white and other colors.

1. Navigator Rail and Stair Systems

A Navigator Rail

- (a) The **Navigator** guardrail system consists of a top rail, bottom rail, balusters, and aluminum reinforcing inserts. The top rail, bottom rail, and balusters are manufactured with PVC (**Solid Core™** Composite) material by the co-extrusion process except for the aluminum baluster and the molded brackets.
- (b) The **Navigator** guardrail system has a top rail that comes in three styles: Capital, Contempo, and Graspable. The top rails have a highly-contoured configuration, are hollow in the center, have rounded edges and have an acrylic cap stock on the rails. The three top rails may have reinforcing stiffener inserts depending on the guardrail span. When a stiffener is required there is one stiffener design for Capital top rail and one stiffener design for the Contempo top rail. The top rails have a U-shape profile sub-rail and are pre-routed for baluster connectors. There is a graspable top rail design that is only used for stair applications (see “B Navigator Stairs” below). See Table 1 in this Report for drawings and dimensions of top rails, stiffeners and sub rail. See Table 2 for top rail stiffener installation requirements.
- (c) The **Navigator** guardrail system has a bottom rail that has a highly-contoured configuration with an attaching sub-

Version 1.0



rail, has rounded edges and is pre-routed for balusters. The bottom rail sub-rail has a U-shape profile. See Table 1 in this Report for drawings and dimensions of the bottom rail and sub-rail.

- (d) The **Navigator** guardrail system has two optional baluster designs as follows: square and round. The square baluster is manufactured with PVC material, is square in shape has rounded edges and is hollow in the center. The round baluster is circular in shape, is hollow in the center and is an extruded 6005-T5 Aluminum material. See Table 1 in this Report for baluster drawings and dimensions.
- (e) The **Navigator** guardrail system connections for the top and bottom rail to the supports are PVC molded brackets. The brackets are secured to the posts with steel screws (stainless, corrosion-resistant, or galvanized) suitable for use in preservative-treated wood. See Table 1 and 3 of this Report for drawing of the bracket and number of fasteners required.
- (f) The **Navigator** guardrail system connections for the balusters to the top and bottom rail are as follows: a PVC adaptor for the square shape baluster and a die-cast Aluminum adaptor that is circular in shape for the Aluminum baluster. See Table 1 of this Report for a drawing of the adaptors.
- (g) See manufacturer's published installation instructions [34117368 Rev 10.22](#) for additional installation details.

B Navigator Stairs

- (a) The **Navigator** guardrail system can be used as stair guards. The top rail has a highly-contoured configuration, hollow in the center, has rounded edges and has an acrylic cap stock on the rail. The top rail has an attached U-shape profile sub-rail that is pre-routed for baluster connectors. See Tables 1, 2 and 3 in this Report for the stair top and bottom rail, for sub-rail, for stair maximum length between posts, bottom rail supports, top and bottom rail connection brackets and fasteners required.
- (b) When the guardrail is used with stairs, the guardrail must be installed in accordance with the manufacturer's published installation instructions, and information located in Table 3 in this Report. When the manufacturer's published installation instructions differ from this Report, this Report governs.
- (c) See manufacturer's published installation instructions [34117570 Rev 10.22](#) for additional installation details.

2. Traverse Rail and Stair Systems

A Traverse Rail

- (a) The guardrail system consists of a top rail, bottom rail, and baluster designs. The top rail, bottom rail, and square baluster are manufactured with PVC material in a co-extrusion process.
- (b) The **Traverse** guardrail system has a T-Rail profile top rail with 0.175-in. wall thickness, hollow in the center, has rounded edges, is pre-routed for balusters and has a PVC cap stock. See Table 4 in this Report for drawings and dimensions.
- (c) The **Traverse** guardrail system has a bottom rail that is rectangular in shape, hollow in the center, has rounded edges and is pre-routed for balusters. The bottom rails connect to the supports utilizing molded PVC brackets. See Table 4 in this Report for drawing and dimensions.
- (d) The **Traverse** guardrail system has a PVC baluster 1-1/2-inch square in shape with 0.065-inch wall nominal wall thickness, has rounded edges and hollow in the center. See Table 4 in this Report for drawings and dimensions.
- (e) The **Traverse** guardrail system connections for the top rail and bottom rail to the supports are brackets. The brackets are secured to the supports with steel screws (stainless, corrosion-resistant, or galvanized) suitable for use in preservative-treated wood. See Tables 4 and 6 in this Report for drawings of the brackets and number of fasteners required.
- (f) See Table 5 in this Report for the **Traverse** guardrail system height and length. The guardrail system that is 6 feet in length requires intermediate support between the supports under the bottom rail and the guardrail system that is 8 feet in length requires two supports that are located under the bottom rail and are evenly spaced between supports.
- (g) See the manufacturer's published installation instructions [34117451 Rev 1.23](#) for additional details.

**B Traverse Stairs**

- (a) The guardrail system can be used as a stair guard. See Table 5 for maximum length between posts, bottom rail supports, top and bottom rail connection brackets and fasteners required.
- (b) When the guardrail is used with stairs, the guardrail must be installed in accordance with the applicable code, manufacturer's installation instructions and Table 6 in this Report. When the manufacturer's installation instructions differ from this Report, this Report governs.
- (c) See Manufacturer's published installation instructions [34117451 Rev 1.23](#) for additional installation details.

3. Discovery Rail and Stair Systems**A Discovery Rail**

- a. The **Discovery** guardrail systems consist of a top rail, bottom rail, balusters, and aluminum reinforcing inserts. The bottom and baluster components (except for the round baluster) are manufactured by the co-extruded process with PVC material. The top rail is manufactured by the co-extruded process with CompositCore™ material.
 - b. The **Discovery** guardrail system has a top rail that has a contoured profile, is hollow in the center, has rounded edges, is pre-routed for balusters, and has a PVC cap stock on the top rail. The top rail has a "dog bone" 6005-T5 aluminum insert that must be used with the 8 foot and 10-foot guardrail systems. The top rail is connected to the supports utilizing a PVC bracket. See Table 7 in this Report for drawings and dimensions.
 - c. The **Discovery** guardrail system has a bottom rail that is rectangular in shape, is hollow in the center, has rounded edges, and is pre-routed for balusters. The bottom rail connects to the supports utilizing a molded PVC bracket. See Table 1 in this Report for drawings and dimensions.
 - d. The **Discovery** guardrail system has two baluster designs, square and a circular shape. The square baluster is extruded with PVC material, and the circular baluster is a round (aluminum 6005-T5) tube. See Tables 7 in this Report for baluster drawings and dimensions.
 - e. The **Discovery** guardrail system connections for the top and bottom rail to the supports are brackets. The brackets are secured to the posts with steel screws (stainless, corrosion plated or galvanized) suitable for use in preservative-treated wood. See Tables 7 and 9 in this Report for drawing of the bracket and number of fasteners required.
 - f. See Table 8 in this Report for the **Discovery** guardrail system height and length. The guardrail system that is 6 feet in length requires intermediate support between the supports under the bottom rail, and the guardrail systems that are 8 feet and 10 feet in length require two supports that are located under the bottom rail and are evenly spaced between the supports.
- (a) See manufacturer's published installation instructions [34117424 Rev 10.22](#).

B Discovery Stairs

- (a) The **Discovery** guardrail system can be used as stair guards. See Tables 7, 8, and 9 in this Report for the maximum length between posts, bottom rail supports, top and bottom rail connection brackets, and fasteners required.
- (b) When guardrails are used with stairs, the guardrail must be installed in accordance with the manufacturer's installation instructions and information located in Table 9 in this Report. When the manufacturer's installation instructions differ from this Report, this Report governs.
- (c) See manufacturer's published installation instructions [34117424 Rev 10.22](#).

4. Posts – Navigator, Traverse, and Discovery

- (a) The **Navigator, Traverse, and Discovery** guardrail systems have post-sleeves and post-sleeve spacers. The post sleeves are manufactured with PVC material, are square in shape, hollow in the center and have rounded edges. The post sleeves are non-structural and can be installed over conventional wood posts. The post sleeve spacer is manufactured with HDPE material, is square in shape, hollow in the center and has rounded edges. Specific details regarding the construction installation for the post sleeves, post sleeve spacer and/or posts have not been evaluated and are outside the scope of this Report. Specific details when required must be furnished to the authority having jurisdiction. See Table 1 of this Report for post sleeve and post sleeve spacer drawings and dimensions.



APPLICABLE CODES:

- 2015, 2018, and 2021 International Building Code (IBC)
- 2015, 2018, and 2021 International Residential Code (IRC)

APPLICABLE CHARACTERISTICS REVIEWED:

1. Structural Performance:

- (a) MoistureShield **Navigator, Traverse, and Discovery** guardrail systems have been reviewed for maximum spans as indicated in Tables 2, 5, and 8 in this Report with the limitations of use evaluated for each design (style).

2. Temperature:

- (a) MoistureShield **Navigator, Traverse, and Discovery** guardrail systems have been reviewed and evaluated for temperature range of -20 °F (-29 °C) to 125 °F (52 °C).

3. Flame Spread Index:

- (a) MoistureShield **Navigator, Traverse, and Discovery** guardrail system flame spread rating was less than 200 for Solidcore and VPC material when tested in accordance with ASTM E84, *Standard Test Method for Surface Burning Characteristics of Building Materials*.

4. Decay Resistance:

- (a) The materials used in the MoistureShield **Navigator, Traverse, and Discovery** guardrail systems in this Report do not contain any wood and have been deemed comparable to naturally resistant wood or to preservative-treated wood for resistance to fungal decay.

5. Termite Resistance:

- (a) The materials used in the MoistureShield **Navigator, Traverse, and Discovery** guardrail systems in this Report do not contain any wood and have been deemed equivalent to naturally resistant wood or to preservative-treated wood for resistance to termite attack.

6. UV Testing:

- (a) The UV testing was conducted, and an appropriate adjustment factor was applied in accordance with ASTM D7032, *Standard Specification for Establishing Performance Ratings for Wood-Plastic Composite Deck Boards and Guardrail Systems (Guards or Handrails)*.

7. Fastening:

- (a) MoistureShield **Navigator, Traverse, and Discovery** guardrail system top and bottom rails must be fastened to posts with PVC molded brackets using steel (stainless, corrosion-resistant, or galvanized) screws. See Table 1, 4, and 7 of this Report for drawing of the bracket. See Table 3, 6, and 9 of this Report and manufacturer's installation instructions for fastening details.
- (b) The fasteners and brackets are supplied by the manufacturer and must be used in the installation of the MoistureShield **Navigator, Traverse, and Discovery** guardrail system. Use of other brackets and fasteners is not covered under this Report.

8. Posts:

- (a) Wood posts or other wood support framing members are not covered under this Report. However, wood posts and other wood support framing members must be designed to meet load and other requirements in the applicable building code(s), have a minimum specific gravity of 0.51 (Southern Pine or better), and of sufficient thickness to allow full penetration of bracket mounting screws.

APPLICABLE USES:

The materials used in the MoistureShield **Transform, Navigator, and Discovery** guardrail systems evaluated in this Report are for installations on construction complying with IRC or IBC. See Table 2, 5, and 8 for guardrail system limitations.



LIMITATIONS OF ACCEPTANCE:

The MoistureShield **Navigator, Traverse, and Discovery** guardrail systems as described in this Report complies with those codes listed in the Applicable Codes section above and is subject to the following conditions.

1. The guardrail systems are limited to exterior construction complying with the IRC and the IBC. The guardrail systems provide a protective barrier for walking areas, balconies, porches, stairs and ramps.
2. Installation of the guardrail systems must comply with this Report; the manufacturer’s published installation instructions, and the applicable code. When the guardrail installation instructions differ from this Report, this Report governs.
3. The fasteners described in this Report have been evaluated for the installation of the MoistureShield **Navigator, Traverse, and Discovery** guardrails and stairs only. Material necessary for anchorage of the guardrail and stair system(s) and compatibility of the fasteners to the treated wood supporting construction have not been evaluated.
4. The guardrail systems indicated in the Report must be fastened to the supporting construction as indicated in the manufacturer’s published installation instructions and as outlined in this Report. When guardrail fastening instructions differ from this Report, this Report governs.
5. The top rail component for the guardrail systems do not meet the graspability requirements when used as a handrail for stairs. In order to comply with the IBC or IRC graspability requirements, a separate handrail complying with IBC Section 1014.3 or IRC Section R311.7.8.3 must be provided. Specific details regarding the construction installation and attachment to the stair guardrail and/or posts have not been evaluated and are outside the scope of this Report. Specific details when required must be furnished to the authority having jurisdiction.
6. When required, the guardrail system, including a stair in this Report must be designed by a professional and submitted to the authority having jurisdiction for final acceptance.
7. The MoistureShield **Transform, Navigator, and Discovery** guardrail systems have not been evaluated as a member of a fire-resistance-rated assembly.
8. MoistureShield has a third-party inspection program provided by PFS TECO.

DOCUMENTATION SUBMITTED:

Submitted data was provided in accordance with PFS TECO Certification and Inspection Policy: Deck Boards and Guardrails (Quality Control Manual, Specifications, Manufacturer’s published installation instructions, Test data and Descriptive information). The products have been evaluated in accordance with ICC-ES AC174, *Acceptance Criteria for Deck Board Span Ratings and Guardrail Systems (Guards and Handrails)*.

PRODUCT IDENTIFICATION:

The MoistureShield guardrail assembly system must be identified with a label on each component or the packaging. The information required is as follows: MoistureShield, product identification (**Navigator, Traverse, or Discovery**), compliance to ASTM D7032 including the maximum guardrail span and loading, the PFS TECO Building Product Evaluation number (BPER 0142), and the PFS Certification Mark (see image below). Guardrails that are 36” high require a label indicating, “Guardrail installation in residential (1 & 2 Family) units only.” Guardrails without this information are not covered under this Report.



Table 1: Schematics of Navigator Guardrail System Components

Description	Profile
Top Rail	<p><i>Capital</i> <i>Contempo</i></p> <p><i>Graspable Stair</i></p>
Bottom Rail	
Sub Rail	
Balusters	<p><i>1-1/8" Square</i> <i>Aluminum</i></p>
Baluster Adaptors	

Description	Profile		
	Square Baluster Plug	Round Baluster Level Plug	Round Baluster Stair Plug
Top Rail Insert (Rail Cap)			
Bracket			
Bottom Rail Support Block			
Post Sleeve	 <p data-bbox="456 1245 711 1270"><i>5x5" Post Sleeve Insert</i></p>	 <p data-bbox="829 1245 1019 1270"><i>5x5" Post Sleeve</i></p>	 <p data-bbox="1154 1245 1344 1270"><i>6x6" Post Sleeve</i></p>



Table 2 Span Table for Navigator Guardrail System

Guardrail Type	Top Rail	Top Rail Stiffener	Baluster	Max Guardrail Span
Railing Assembly for Compliance with IRC Maximum Rail Height 36 inches				
Level / In-Line Level / 45°	Contempo	No	¾" Aluminum 1-1/8" Square Solidcore	96-in.
	Capital			
Stair	Contempo	No	¾" Aluminum 1-1/8" Square Solidcore	92-in.
	Capital			
	Graspable			69-in.
Railing Assembly for Compliance with IBC Maximum Rail Height 42 inches				
Level / In-Line	Contempo	Yes	¾" Aluminum 1-1/8" Square Solidcore	96-in.
	Capital			
	Contempo	No		91-in.
	Capital			
Stair	Contempo	No	72-in.	
	Capital			

for SI conversion: 1 in = 25.4 mm, 1 psf = 47.9 Pa, 1 lbf = 0.0044 kN

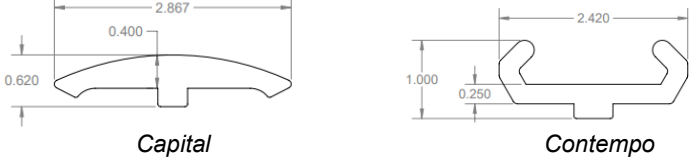
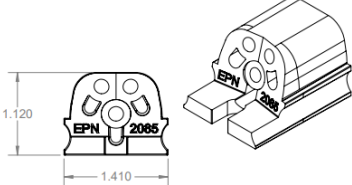
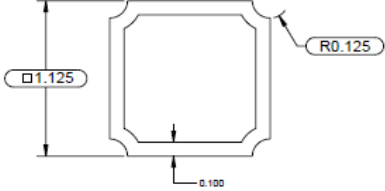
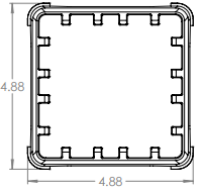
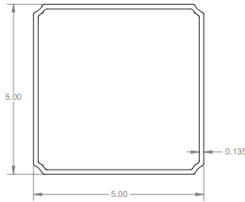
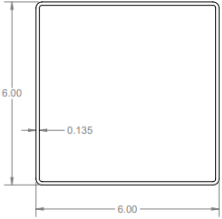
Refer to Table 3 for fastening schedule.

Maximum span is clear length between posts measured parallel to top/bottom rail.

Table 3: Fastening Schedule for Navigator Guardrail Assembly

Location	Connection	Fasteners
Top Rail	Bracket to Post	Three #10 x 2-1/2" Pan #2 Square Drive SDS 410 SS screw
	Bracket to Sub Rail	One #6 x 3/4" trim-head, Philips drive, 18-8 SS screw
	Sub-Rail to Bracket to Rail-Cap	Two #10 x 2" Pan #2 Square Drive SDS SS screw
	Baluster Adaptors to Rail	Slip Fit
	Baluster to Baluster Adaptors	Slip Fit
Bottom Rail	Bracket to Post	Three #10 x 2-1/2" Pan #2 Square Drive SDS 410 SS screw
	Bracket to Sub Rail	One #6 x 3/4" trim-head, Philips drive, 18-8 SS screw
	Sub-Rail to Bracket to Rail-Cap	Two #10 x 2" Pan #2 Square Drive SDS 410 SS screw
	Baluster Adaptors to Rail	Slip Fit
	Baluster to Baluster Adaptors	Slip Fit
	Rail to Support Block	One #12 x 5" trim-head, square drive, bugle head, 18-8 SS screw ¹

¹ Pre drill with 1/4" drill bit

Table 4: Schematics of Traverse Guardrail System Components

Description	Profile
Top Rail	
Bottom Rail	
Balusters	<p>PVC Square Aluminum Round</p>
T-Rail Level Rail Brackets	<p>Top Rail Top Brackets Top Rail Bracket Cover Bottom Rail Bracket</p> <p>Top Rail Angle Bracket Bottom Rail Angle Bracket</p>

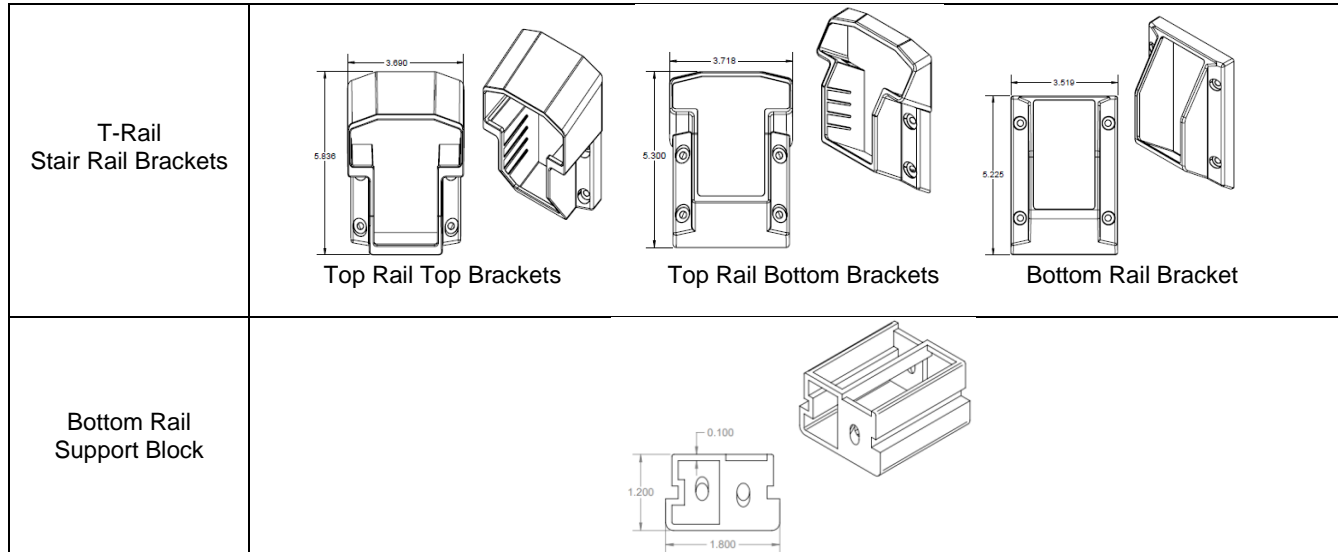

**Table 5: Maximum Span Table for Traverse Guardrail Assembly
(Max. Guardrail Height 36 in. for IRC Residential Dwellings – (TYPE V-B))**

Guardrail Type	Top Rail	Top Rail Insert	Bottom Rail Insert	Baluster	Max Guardrail Length
Level	T-Rail	None	None	1.5x1.5 Square 0.75 Aluminum	96-in.
Stair	T-Rail	None	None	1.5x1.5 Square 0.75 Aluminum	90-in.

for SI conversion: 1 in = 25.4 mm, 1 psf = 47.9 Pa, 1 lbf = 0.0044 kN

Refer to Table 6 for fastening schedule

Maximum span is clear length between posts measured parallel to top/bottom rail



Table 6: Fastening Schedule for Traverse Guardrail Assembly

Location	Connection	Fasteners
Level Rail Assembly		
T-Rail Level Top Rail with PVC Bracket	Rail Bracket to Post	Four #10 x 2" Pan #2 Square Drive SDS 410 SS screw
	Rail Bracket to Rail	Three #10 x 1-1/4" Pan #2 Square Drive SDS 410 SS screw
T-Rail Level Top Rail with Adjustable Bracket	Rail Bracket Base to Post	Four #10 x 1-1/2" Pan Phillips Drive SDS 410 SS screw
	Rail Bracket to Rail	Two #10 x 1" Flat Head #2 Square Drive SDS 410 SS screw ¹
	Rail Bracket to Bracket Base	Two #10 x 1" Pan Head Phillips Drive SDS 410 SS screw
Bottom Rail Level with PVC Bracket	Rail Bracket to Post	Four #10 x 1-1/4" Pan #2 Square Drive SDS 302 SS screw ¹
	Rail Bracket to Rail	Slip fit – No mechanical connection
Bottom Rail Level with Optional PVC Bracket	Rail Bracket to Post	Two #10 x 1-1/4" Pan #2 Square Drive SDS 302 SS screw ¹
	Rail Bracket to Rail	Slip fit – No mechanical connection
Stair Rail Assembly		
T-Rail Top Rail Stair with Molded PVC Bracket	Rail Bracket to Post	Four #10 x 1-1/2" Pan #2 Square Drive SDS 410 SS screw
	Rail Bracket to Rail (Optional)	One #10 x 1" Pan #2 Square Drive SDS 410 SS screw
Bottom Rail Stair Molded PVC Bracket	Rail Bracket to Post	Four #10 x 1-1/4" Pan #2 Square Drive SDS 410 SS screw ¹
	Rail Bracket to Rail	Slip fit – No mechanical connection
Bottom Rail Stair with Angle Wizard Bracket	Rail Bracket Base to Post	Four #10 x 1-1/2" Pan #2 Square Drive SDS 410 SS screw ²
	Rail Bracket to Rail	Slip fit – No mechanical connection
	Rail Bracket to Bracket Base	One #10 x Pan 18-8 SS screw
Support Block ³ to Bottom Rail		One #10 x 3/4" Pan #2 Square Drive Tapping 302 SS screw

¹ Pre drill with 5/32" drill bit

² Pre drill with 1/8" drill bit

³ Use one Support Block for 6-ft span and two Support Blocks for longer span

⁴ See Applicable Characteristics Reviewed – 8 for additional post information

Table 7: Schematics of Discovery Guardrail System Components

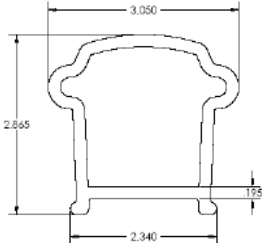
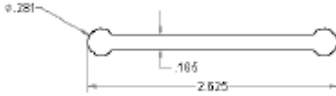
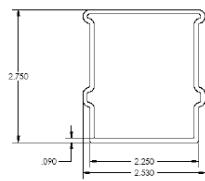
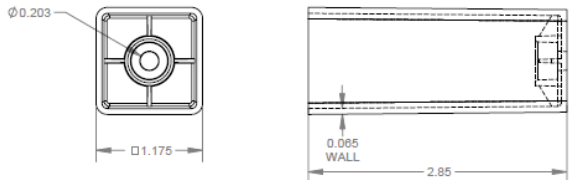
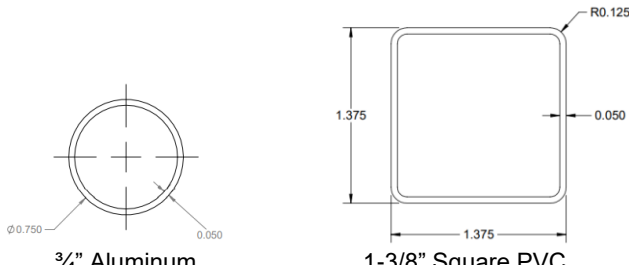
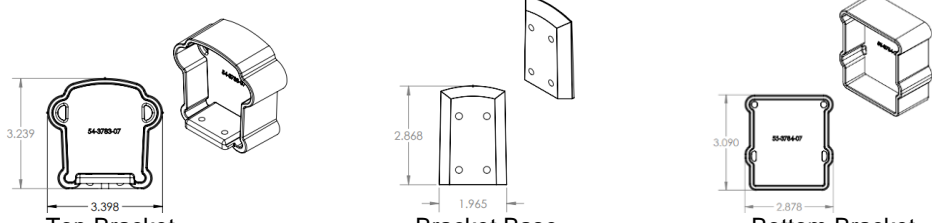
Description	Profile
Top Rail	
Top Rail Insert	 <p style="text-align: center;">Dog Bone</p>
Bottom Rail	
Bottom Rail Insert	None
Bottom Rail Support Block	
Baluster	 <p style="text-align: center;">3/4" Aluminum 1-3/8" Square PVC</p>
Bracket - Level	 <p style="text-align: center;">Top Bracket Bracket Base Bottom Bracket</p>

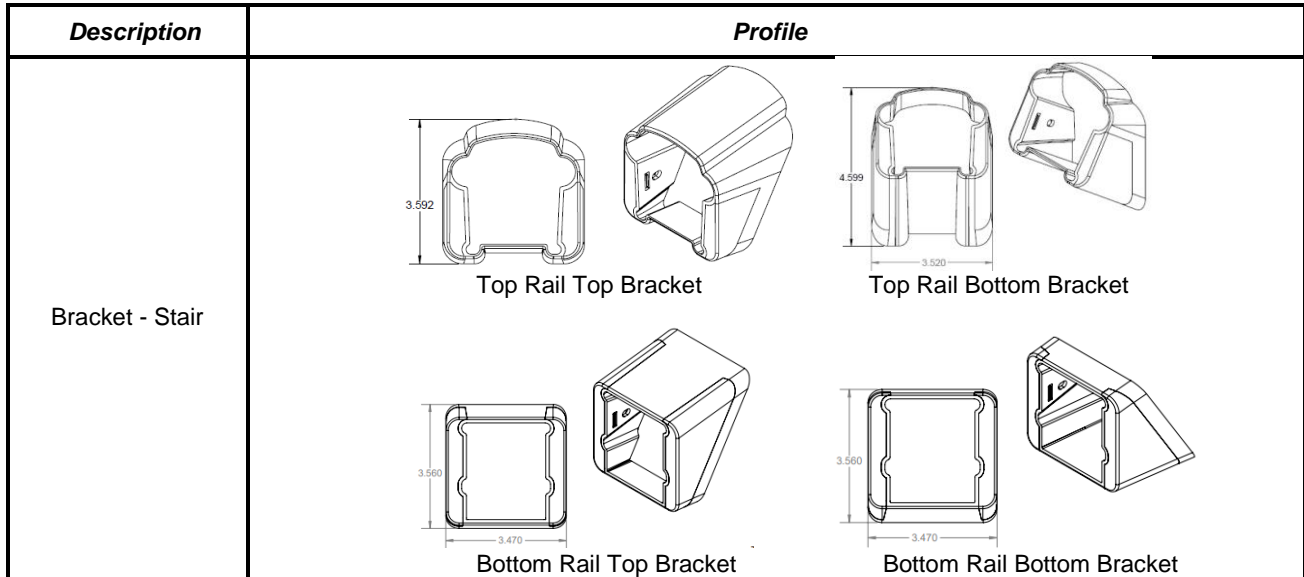

Table 8: Span Table for Discovery Guardrail System

Guardrail Type	Top Rail Stiffener	Baluster	Max Guardrail Span
Railing Assembly for Compliance with IRC Maximum Rail Height 36 inches			
Level	None	1-3/8" Square 0.055" Thick, 3/4" Aluminum	67
	Dog Bone		115
Stair	Dog Bone		90
Railing Assembly for Compliance with IBC Maximum Rail Height 42 inches			
Level	None	1-3/8" Square 0.055" Thick, 3/4" Aluminum	67
	Dog Bone		91
Stair	Dog Bone		90

for SI conversion: 1 in = 25.4 mm, 1 psf = 47.9 Pa, 1 lbf = 0.0044 kN

Refer to Table 8 for fastening schedule.

Maximum span is clear length between posts measured parallel to top/bottom rail.



Table 9: Fastening Schedule for Discovery Guardrail Assembly

Location	Connection	Fasteners
Level – Top Rail Bracket Base	Base to Post	Four #10 x 2" Pan #2 Square Drive SDS 410 SS screw ¹
	Rail Bracket to Base	Slip fit – No mechanical connection
Level – Top Rail (Rail Bracket)	Rail Bracket to Post	Two #10 x 2" Pan #2 Square Drive SDS 410 SS screw
	Rail Bracket to Rail	Two #10 x 2" Pan #2 Square Drive SDS 410 SS screw
Level - Bottom Rail, Bracket Base	Base to Post	Four #10 x 1-1/4" Pan #2 Square Drive, 302 SS screw ¹
	Rail Bracket to Base	Slip fit – No mechanical connection
Level - Bottom Rail Rail Bracket	Rail Bracket to Post	Slip fit – No mechanical connection
	Rail Bracket to Rail	Slip fit – No mechanical connection on 8' or less One #10 x 1" Pan #2 Square Drive SDS 410 SS screw ¹ for 10' rail
Stair – Top Rail	Rail Bracket to Post	Four #10x2" Pan #2 Square Drive SDS 410 SS screw
	Rail Bracket to Rail	One #10x1" Pan #2 Square Drive SDS 410 SS screw
Stair – Top Rail Lower Socket	Rail Bracket to Post	Two #10x1-1/4" Pan #2 Square Drive SDS 410 SS screw
	Rail Bracket to Rail	none
Support Block to Bottom Rail (Level)		One #10 x 3/4" Pan #2 Square Drive Tapping 302 SS screw

¹ Pre drill with 5/32" drill bit

² Use one Support Block for 6-ft span and two Support Blocks for longer span



BPER 0142 Revision History		
Version	Revision Date	Description
1.0	May 11, 2023	Initial Approval